

OPERATION MANUAL



WHISPERWATT™ SERIES
MODEL DCA40SSKU4F2
60Hz Generator
(KUBOTA V2403-CR-TIE4BG DIESEL ENGINE)

Revision #1 (01/18/18)

To find the latest revision of this
publication, visit our website at:
www.mqpower.com



THIS MANUAL MUST ACCOMPANY THE EQUIPMENT AT ALL TIMES.



CALIFORNIA — Proposition 65 Warning

Diesel engine exhaust and some of its constituents are known to the State of California to cause cancer, birth defects and other reproductive harm.

REPORTING SAFETY DEFECTS

If you believe that your vehicle has a defect that could cause a crash or could cause injury or death, you should immediately inform the National Highway Traffic Safety Administration (NHTSA) in addition to notifying Multiquip at 1-800-421-1244.

If NHTSA receives similar complaints, it may open an investigation, and if it finds that a safety defect exists in a group of vehicles, it may order a recall and remedy campaign. However, NHTSA cannot become involved in individual problems between you, your dealer, or Multiquip.

To contact NHTSA, you may either call the Vehicle Safety Hotline toll-free at 1-888-327-4236 (TTY: 1-800-424-9153), go to <http://www.nhtsa.dot.gov>; or write to:

Administrator
NHTSA
1200 New Jersey Avenue S.E.
Washington, DC 20590

You can also obtain information about motor vehicle safety from <http://www.safecar.gov>.

DCA40SSKU4F2 60 Hz Generator

Proposition 65 Warning	2
Reporting Safety Defects.....	3
Table Of Contents.....	4
Nameplate/Safety Information	5
Safety Information	6-11
Specifications	12
Dimensions.....	13
Installation	14-15
General Information.....	16
Major Components	17
Engine Control Panel.....	18-19
Generator Control Panel.....	20
Output Terminal Panel Familiarization	21-23
Load Application	24
Generator Outputs.....	25
Generator Outputs/Gauge Reading.....	26
Output Terminal Panel Connections	27-28
Inspection/Setup.....	29-32
Generator Start-Up Procedure (Manual)	33-35
Generator Start-Up Procedure (Auto).....	36
Generator Shut-Down Procedures	37
Maintenance	38-45
Troubleshooting Diagnostics.....	46
Troubleshooting (Generator).....	47
Generator Wiring Diagram.....	48
Engine Wiring Diagram.....	49
Battery Charger Wiring Diagram	50
Engine Block Heater Wiring Diagram	51

NOTICE

Specifications are subject to change without notice.

NAMEPLATE/SAFETY INFORMATION

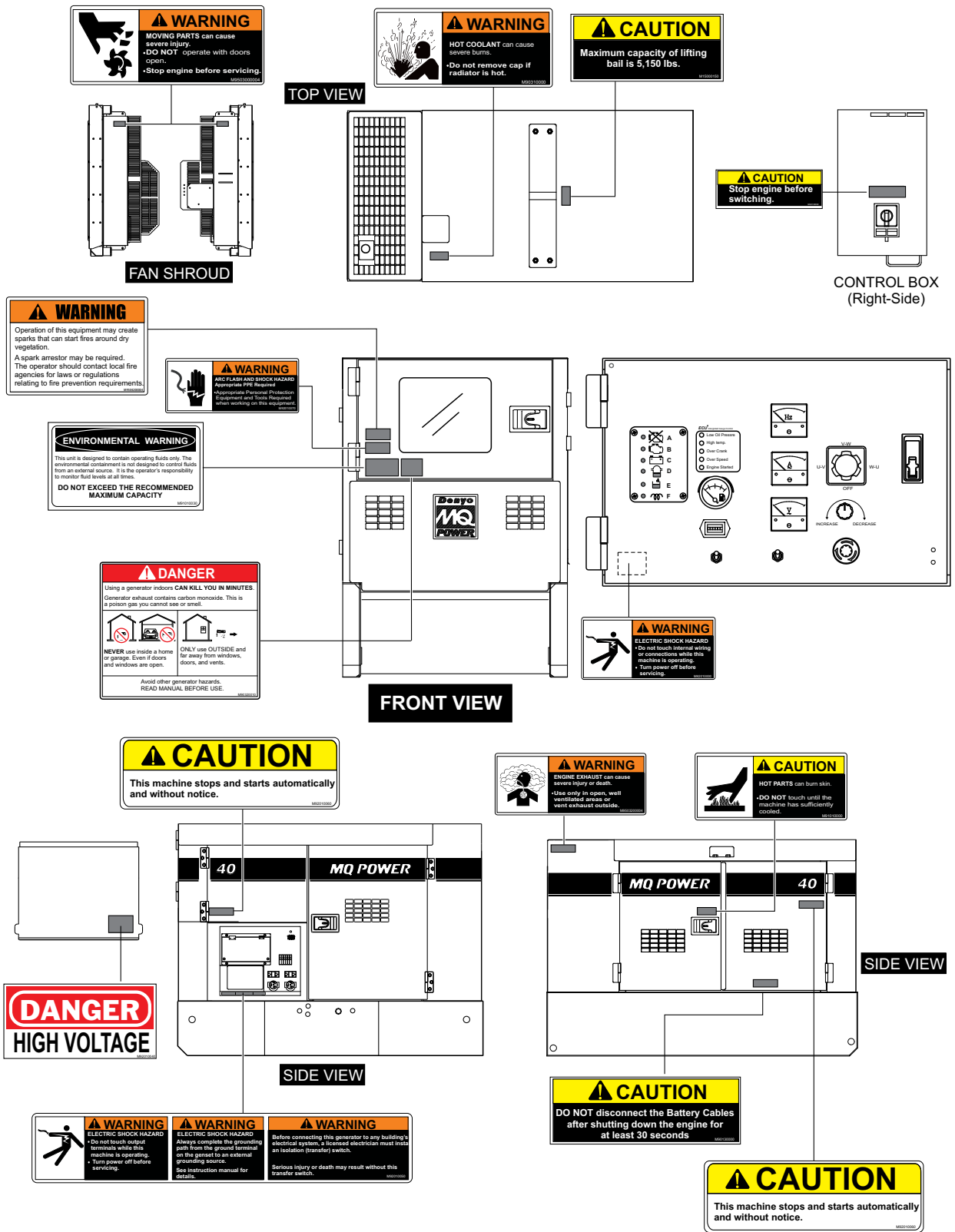

SAFETY INFORMATION

DO NOT operate or service the generator before reading the entire manual. Safety precautions should be followed at all times when operating this generator. Failure to read and understand the safety messages and operating instructions could result in injury to yourself and others.

SAFETY MESSAGES

The four safety messages shown below will inform you about potential hazards that could injure you or others. The safety messages specifically address the level of exposure to the operator and are preceded by one of four words: **DANGER**, **WARNING**, **CAUTION** or **NOTICE**.

SAFETY SYMBOLS

⚠ DANGER

Indicates a hazardous situation which, if not avoided, **WILL** result in **DEATH** or **SERIOUS INJURY**.

⚠ WARNING

Indicates a hazardous situation which, if not avoided, **COULD** result in **DEATH** or **SERIOUS INJURY**.







⚠ CAUTION

Indicates a hazardous situation which, if not avoided, **COULD** result in **MINOR** or **MODERATE INJURY**.

NOTICE

Addresses practices not related to personal injury.

Potential hazards associated with the operation of this generator will be referenced with hazard symbols which may appear throughout this manual in conjunction with safety messages.

Symbol	Safety Hazard
	Lethal exhaust gas hazards
	Explosive fuel hazards
	Burn hazards
	Overspeed hazards
	Rotating parts hazards
	Pressurized fluid hazards
	Electric shock hazards

SAFETY INFORMATION

GENERAL SAFETY

CAUTION

- **NEVER** operate this generator without proper protective clothing, shatterproof glasses, respiratory protection, hearing protection, steel-toed boots and other protective devices required by the job or city and state regulations.



- **NEVER** operate this generator when not feeling well due to fatigue, illness or when under medication. 
- **NEVER** operate this generator under the influence of drugs or alcohol.



- **ALWAYS** check the generator for loosened threads or bolts before starting.
- **DO NOT** use the generator for any purpose other than its intended purposes or applications.

NOTICE

- This generator should only be operated by trained and qualified personnel 18 years of age and older.
- Whenever necessary, replace nameplate, operation and safety decals when they become difficult to read.
- Manufacturer does not assume responsibility for any accident due to generator modifications. Unauthorized generator modification will void all warranties.

- **NEVER** use accessories or attachments that are not recommended by MQ Power for this generator. Damage to the generator and/or injury to user may result.

- **ALWAYS** know the location of the nearest **fire extinguisher**.



- **ALWAYS** know the location of the nearest **first aid kit**.



- **ALWAYS** know the location of the nearest phone or **keep a phone on the job site**. Also, know the phone numbers of the nearest **ambulance, doctor and fire department**. This information will be invaluable in the case of an emergency.

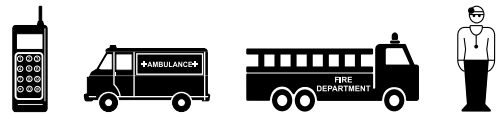

GENERATOR SAFETY

DANGER

- **NEVER** operate the generator in an explosive atmosphere or near combustible materials. An explosion or fire could result causing severe **bodily harm or even death**.



WARNING

- **NEVER** disconnect any **emergency or safety devices**. These devices are intended for operator safety. Disconnection of these devices can cause severe injury, bodily harm or even death. Disconnection of any of these devices will void all warranties.

CAUTION

- **NEVER** lubricate components or attempt service on a running machine.

NOTICE

- **ALWAYS** ensure generator is on level ground before use.
- **ALWAYS** keep the generator in proper running condition.
- Fix damage to generator and replace any broken parts immediately.
- **ALWAYS** store generator properly when it is not being used. Generator should be stored in a clean, dry location out of the reach of children and unauthorized personnel.

SAFETY INFORMATION

ENGINE SAFETY

DANGER

- The engine fuel exhaust gases contain poisonous carbon monoxide. This gas is colorless and odorless, and can cause death if inhaled.
- The engine in this generator requires an adequate free flow of cooling air. **NEVER** operate this generator in any enclosed or narrow area where free flow of the air is restricted. If the air flow is restricted it will cause injury to people and property and serious damage to the generator or engine.

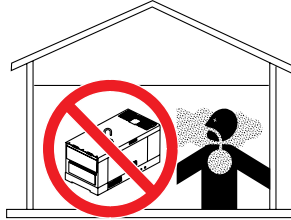

WARNING

- **DO NOT** place hands or fingers inside engine compartment when engine is running.
- **NEVER** operate the engine with heat shields or guards removed.
- Keep fingers, hands hair and clothing away from all moving parts to prevent injury.
- **DO NOT** remove the radiator cap while the engine is hot. High pressure boiling water will gush out of the radiator and severely scald any persons in the general area of the generator.
- **DO NOT** remove the coolant drain plug while the engine is hot. Hot coolant will gush out of the coolant tank and severely scald any persons in the general area of the generator.



CAUTION

- **NEVER** touch the hot exhaust manifold, muffler or cylinder. Allow these parts to cool before servicing generator.



NOTICE

- **NEVER** run engine without an air filter or with a dirty air filter. Severe engine damage may occur. Service air filter frequently to prevent engine malfunction.
- **NEVER** tamper with the factory settings of the engine or engine governor. Damage to the engine or generator can result if operating in speed ranges above the maximum allowable.
- Wet stacking is a common problem with diesel engines which are operated for extended periods with light or no load applied. When a diesel engine operates without sufficient load (less than 40% of the rated output), it will not operate at its optimum temperature. This will allow unburned fuel to accumulate in the exhaust system, which can foul the fuel injectors, engine valves and exhaust system, including turbochargers, and reduce the operating performance.



In order for a diesel engine to operate at peak efficiency, it must be able to provide fuel and air in the proper ratio and at a high enough engine temperature for the engine to completely burn all of the fuel.

Wet stacking does not usually cause any permanent damage and can be alleviated if additional load is applied to relieve the condition. It can reduce the system performance and increase maintenance. Applying an increasing load over a period of time until the excess fuel is burned off and the system capacity is reached usually can repair the condition. This can take several hours to burn off the accumulated unburned fuel.

- State Health Safety Codes and Public Resources Codes specify that in certain locations, spark arresters must be used on internal combustion engines that use hydrocarbon fuels. A spark arrester is a device designed to prevent accidental discharge of sparks or flames from the engine exhaust. Spark arresters are qualified and rated by the United States Forest Service for this purpose. In order to comply with local laws regarding spark arresters, consult the engine distributor or the local Health and Safety Administrator.

SAFETY INFORMATION

FUEL SAFETY

DANGER

- **DO NOT** start the engine near spilled fuel or combustible fluids. Diesel fuel is extremely flammable and its vapors can cause an explosion if ignited.
- **ALWAYS** refuel in a well-ventilated area, away from sparks and open flames.
- **ALWAYS** use extreme caution when working with **flammable** liquids.
- **DO NOT** fill the fuel tank while the engine is running or hot.
- **DO NOT** overfill tank, since spilled fuel could ignite if it comes into contact with hot engine parts or sparks from the ignition system.
- Store fuel in appropriate containers, in well-ventilated areas and away from sparks and flames.
- **NEVER** use fuel as a cleaning agent.
- **DO NOT** smoke around or near the generator. Fire or explosion could result from fuel vapors or if fuel is spilled on a hot engine.



ELECTRICAL SAFETY

DANGER

- **DO NOT** touch output terminals during operation. Contact with output terminals during operation can cause **electrocution, electrical shock or burn**.
- The electrical voltage required to operate the generator can cause severe injury or even death through physical contact with live circuits. Turn generator and all circuit breakers **OFF** before performing maintenance on the generator or making contact with output terminals.
- **NEVER** insert any objects into the output receptacles during operation. This is extremely dangerous. The possibility exists of **electrical shock, electrocution or death**.



- Backfeed to a utility system can cause **electrocution** and/or property damage. **NEVER** connect the generator to a building's electrical system without a transfer switch or other approved device. All installations should be performed by a **licensed electrician** in accordance with all applicable laws and electrical codes. Failure to do so could result in electrical shock or burn, causing **serious injury or even death**.



Power Cord/Cable Safety

DANGER

- **NEVER** let power cords or cables **lay in water**.
- **NEVER stand in water** while AC power from the generator is being transferred to a load.
- **NEVER** use **damaged** or **worn** cables or cords when connecting generator to generator. Inspect for cuts in the insulation.
- **NEVER** grab or touch a live power cord or cable with wet hands. The possibility exists of **electrical shock, electrocution or death**.
- Make sure power cables are securely connected to the generator's output receptacles. Incorrect connections may cause electrical shock and damage to the generator.

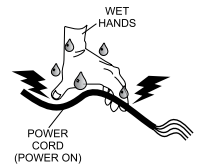

NOTICE

- **ALWAYS** make certain that proper power or extension cord has been selected for the job. See Cable Selection Chart in this manual.

SAFETY INFORMATION

Grounding Safety

DANGER

- This generator is equipped with a grounding terminal attached to the enclosure. Electrical grounding requirements can differ by State, Province, District, Municipality, and unique application settings.
- For portable and vehicle-mounted generators, Multiquip recognizes the guidance provided in NEC Handbook Article 250.34 Parts A and B, and 29 CFR 1926.404 (f) (3) (i). If a more definitive earth-to-ground safeguard is required, please consult a qualified electrician and reference appropriate National Electrical Code (NEC) guidelines in establishing an exterior grounding point generator.
- **NEVER** use gas piping as an electrical ground.

NOTICE

- There is a permanent conductor **bond** between generator (stator winding) and the frame.

BATTERY SAFETY

DANGER

- **DO NOT** drop the battery. There is a possibility that the battery will explode.
- **DO NOT** expose the battery to open flames, sparks, cigarettes, etc. The battery contains combustible gases and liquids. If these gases and liquids come into contact with a flame or spark, an explosion could occur.



WARNING

- **ALWAYS** wear safety glasses when handling the battery to avoid eye irritation. The battery contains acids that can cause injury to the eyes and skin. 
- Use well-insulated gloves when picking up the battery.
- **ALWAYS** keep the battery charged. If the battery is not charged, combustible gas will build up.
- **ALWAYS** recharge the battery in a well-ventilated environment to avoid the risk of a dangerous concentration of combustible gasses.
- If the battery liquid (dilute sulfuric acid) comes into contact with **clothing or skin**, rinse skin or clothing immediately with plenty of water.
- If the battery liquid (dilute sulfuric acid) comes into contact with **eyes**, rinse eyes immediately with plenty of water and contact the nearest doctor or hospital to seek medical attention.

CAUTION

- **ALWAYS** disconnect the **NEGATIVE battery terminal** before performing service on the generator.
- **ALWAYS** keep battery cables in good working condition. Repair or replace all worn cables.

ENVIRONMENTAL SAFETY/DECOMMISSIONING

NOTICE

Decommissioning is a controlled process used to safely retire a piece of generator that is no longer serviceable. If the generator poses an unacceptable and unrepairable safety risk due to wear or damage or is no longer cost effective to maintain (beyond life-cycle reliability) and is to be decommissioned (demolition and dismantlement), be sure to follow rules below.

- **DO NOT** pour waste or oil directly onto the ground, down a drain or into any water source.
- Contact your country's Department of Public Works or recycling agency in your area and arrange for proper disposal of any electrical components, waste or oil associated with this generator.
- When the life cycle of this generator is over, remove battery(s) and bring to an appropriate facility for lead reclamation. Use safety precautions when handling batteries that contain sulfuric acid.
- When the life cycle of this generator is over, it is recommended that the generator frame and all other metal parts be sent to a recycling center.



Metal recycling involves the collection of metal from discarded products and its transformation into raw materials to use in manufacturing a new product. Recyclers and manufacturers alike promote the process of recycling metal. Using a metal recycling center promotes energy cost savings.

EMISSIONS INFORMATION

NOTICE

The diesel engine used in this generator has been designed to reduce harmful levels of carbon monoxide (CO), hydrocarbons (HC) and nitrogen oxides (NOx) contained in diesel exhaust emissions.

This engine has been certified to meet US EPA Evaporative emissions requirements in the installed configuration.

Attempting to modify or make adjustments to the engine emission system by unauthorized personnel without proper training could damage the generator or create an unsafe condition.

Additionally, modifying the fuel system may adversely affect evaporative emissions, resulting in fines or other penalties.

Emission Control Label

The emission control label is an integral part of the emission system and is strictly controlled by regulations.

The label must remain with the engine for its entire life.

If a replacement emission label is needed, please contact your authorized engine distributor.

SPECIFICATIONS

Table 1. Generator Specifications

Model	DCA-40SSKU4F2	
Type	Revolving field, self ventilated, open protected type synchronous generator	
Armature Connection	Star with Neutral	Zigzag
Phase	3	Single
Standby Output	30.2 KW (37.8 kVA)	27.3 KW
Prime Output	28.8 KW (36 kVA)	26 KW
3Ø Voltage (L-L/L-N) Voltage Selector Switch at 3Ø 240/139	208Y/120, 220Y/127, 240Y/139	N/A
3Ø Voltage (L-L/L-N) Voltage Selector Switch at 3Ø 480/277	416Y/240, 440Y/254, 480Y/277	N/A
1Ø Voltage (L-L/L-N) Voltage Selector Switch at 1Ø 240/120	N/A	240/120
Power Factor	0.8	1.0
Frequency	60 Hz	
Speed	1800 rpm	
Aux. AC Power	Single Phase, 60 Hz	
Aux. Voltage/Output	4.8 Kw (2.4 kW x 2)	
Dry Weight	2,205 lbs. (1,000 kg)	
Wet Weight	2,735 lbs. (1,240 kg)	

Table 2. Engine Specifications

Model	Kubota V2403-CR-TIE4BG, Tier 4 Final Certified	
Type	4-cycle, water cooled, direct injection, turbocharged, EGR, ECM, and DOC	
No. of Cylinders	4 cylinders	
Bore x Stroke	3.42 x 4.01 in. (87 x 102 mm)	
Displacement	149 in ³ (2.43 liters)	
Rated Output	48.3 HP at 1800 rpm	
Starting	Electric	
Coolant Capacity	2.77 gal. (10.5 liters)	
Lube Oil Capacity	2.56 gal. (9.7 liters)	
Engine Oil Type	API service class CJ-4 or JASO DH-2	
Fuel Type	Ultra Low Sulfur No. 2 Diesel Fuel	
Fuel Tank Capacity	67.4 gal. (255 liters)	
Fuel Consumption	2.3 gal. (8.7 L)/hr at full load	1.8 gal. (6.7 L)/hr at 3/4 load
	1.3 gal. (5.1 L)/hr at 1/2 load	0.8 gal. (3.0 L)/hr at 1/4 load
Battery	27 (CCA 0° 800A) x 1	

DIMENSIONS

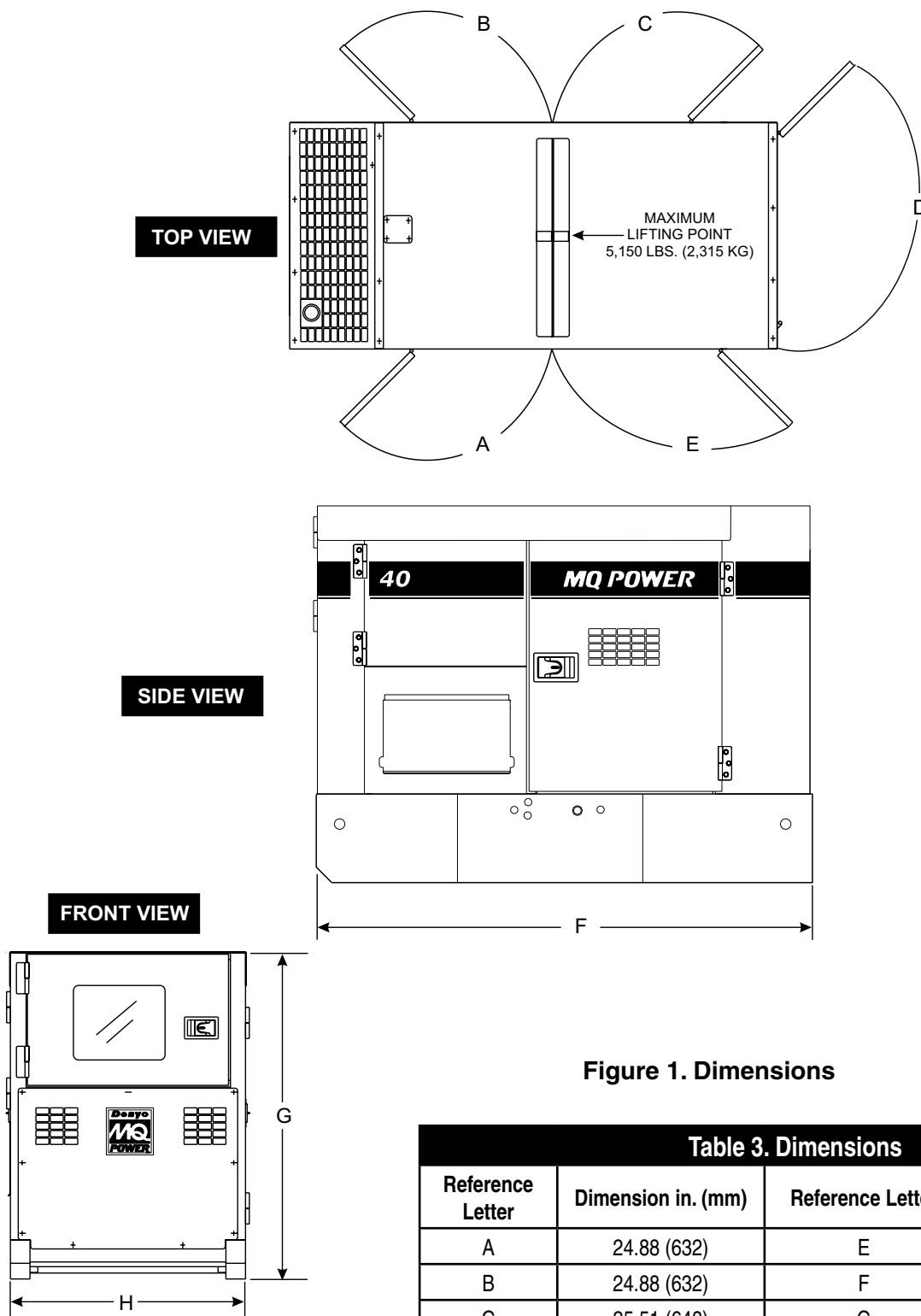

Figure 1. Dimensions

Table 3. Dimensions			
Reference Letter	Dimension in. (mm)	Reference Letter	Dimension in. (mm)
A	24.88 (632)	E	25.51 (648)
B	24.88 (632)	F	76.38 (1,940)
C	25.51 (648)	G	53.15 (1,350)
D	32.28 (820)	H	37.40 (950)

INSTALLATION

CONNECTING THE GROUND

Consult with local Electrical and Safety Codes for proper connection based on condition of use.

EXAMPLE of how to ground the unit if the condition of use requires such a device:

The ground terminal on the generator should always be used to connect the generator to a suitable ground when required.

The ground cable should be #8 size wire (aluminum) minimum. If copper wire is used, #10 size wire minimum should be used.

Connect one end of the ground cable terminal to the generator ground point (Figure 2). Connect the other end of the ground cable to a suitable earth ground (ground rod).

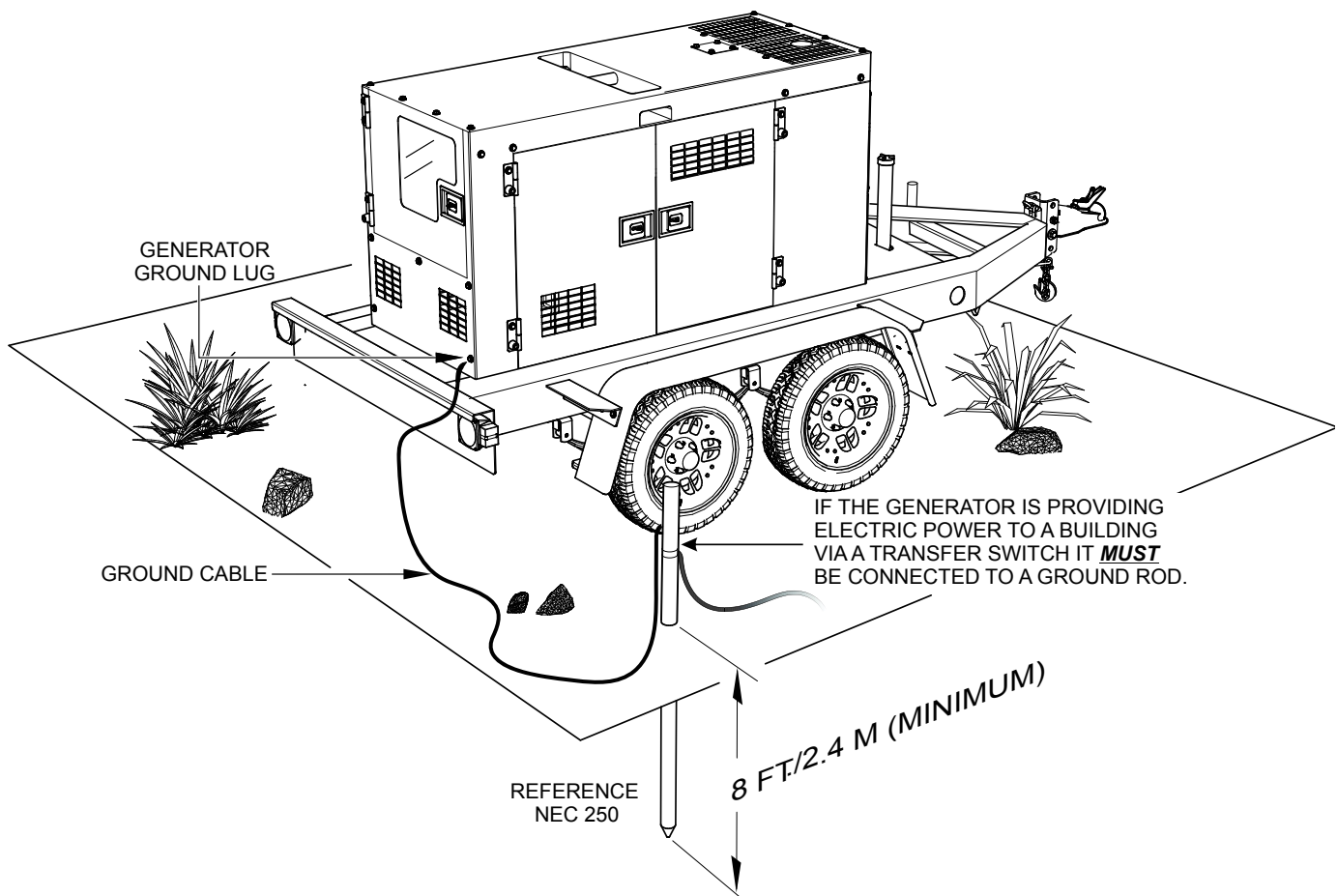

Figure 2. Typical Generator Grounding Application

OUTDOOR INSTALLATION

Install the generator in a area that is free of debris, bystanders, and overhead obstructions. Make sure the generator is on secure level ground so that it cannot slide or shift around. Also install the generator in a manner so that the exhaust will not be discharged in the direction of nearby homes.

The installation site must be relatively free from moisture and dust. All electrical equipment should be protected from excessive moisture. Failure to do will result in deterioration of the insulation and will result in short circuits and grounding.

Foreign materials such as dust, sand, lint and abrasive materials have a tendency to cause excessive wear to engine and alternator parts.

CAUTION

Pay close attention to ventilation when operating the generator inside tunnels and caves. The engine exhaust contains noxious elements. Engine exhaust must be routed to a ventilated area.

INDOOR INSTALLATION

Exhaust gases from diesel engines are extremely poisonous. Whenever an engine is installed indoors the exhaust fumes must be vented to the outside. The engine should be installed at least two feet from any outside wall. Using an exhaust pipe which is too long or too small can cause excessive back pressure which will cause the engine to heat excessively and possibly burn the valves.

MOUNTING

The generator must be mounted on a solid foundation (such as concrete) and set firmly on the foundation to isolate vibration of the generator when it is running. The generator must set at least 6 inches above the floor or grade level (in accordance to NFPA 110, Chapter 54.1). **DO NOT** remove the metal skids on the bottom of the generator. They are to resist damage to the bottom of the generator and to maintain alignment.

GENERATOR GROUNDING

NOTICE

The Occupational Safety and Health Administration (OSHA) and the National Electrical Code (NEC) recommend that if the generator is providing electrical power to a structure (home, office shop, trailer or similar) it **must** be connected to a grounding electrode system, such a driven ground rod ().

If applicable, to guard against electrical shock and possible damage to the equipment, it is important to provide a good **EARTH** ground, (Figure 2).

NOTICE

ALWAYS check with State, Province, District and Municipalities for electrical grounding requirements before using generator.

Article 250 (Grounding) of the NEC handbook provides guidelines for proper grounding and specifies that the cable ground shall be connected to the grounding system of the building as close to the point of cable entry as practical.

NEC article 250 specifies the following grounding requirements:

1. Use one of the following wire types to connect the generator to earth ground.
 - a. Copper 10 AWG (5.3 mm²) or larger.
 - b. Aluminum 8 AWG (8.4 mm²) or larger.
2. When grounding of the generator (Figure 2) is required, connect one end the ground cable to the ground lug on the generator. Connect the other end of the ground cable to the ground rod (earth ground).
3. NEC article 250 specifies that the earth ground rod should be buried a minimum of 8 ft. into the ground.

NOTICE

When connecting the generator to any buildings electrical system **ALWAYS** consult with a licensed electrician.

GENERATOR

This MQ Power generator (Figure 3) is a high quality portable (requires a trailer for transport) power source for telecom sites, lighting facilities, power tools, submersible pumps and other industrial and construction machinery.

ENGINE CONTROL PANEL

The “Engine Operating Panel” is provided with the following:

- Engine Warning Lamp Module
 - Engine Shutdown LED
 - Engine Pre-Alarm LED
 - Charging Battery LED
 - Pre-Heat LED
 - Fuel Filter Water Level LED
 - Fuel Leak Detected LED
- Fuel Gauge
- Auto-Start Controller
- Hour Meter
- Speed Control Switch
- Auto Start Switch
- Diagnostic Switch
- Emergency Stop Button (Optional)

GENERATOR CONTROL PANEL

The “Generator Control Panel” is provided with the following:

- Frequency Meter (Hz)
- AC Ammeter (Amps)
- AC Voltmeter (Volts)
- Ammeter Change-Over Switch
- Voltage Regulator
- 3-Pole, 110 amp Main Circuit Breaker
- “Control Box” (Located Behind Eng/Gen Control Panel)
 - Automatic Voltage Regulator
 - Current Transformer
 - Over-Current Relay
 - Starter Relay
 - Voltage Selector Switch

OUTPUT TERMINAL PANEL

The “Output Terminal Panel” is provided with the following:

- Two 250 VAC output receptacles (CS-6369), 50 amps
- Two auxiliary circuit breakers, 250V @50 amps
- Two 125 VAC output receptacles, (GFCI), 20 amps
- Two duplex circuit breakers, 125V@ 20 amps
- Five output terminal lugs (3Ø power)

OPTIONS

- Battery Charger
- Water Heater
- Low Coolant Level Switch/Indicator
- Camlock Connectors
- Emergency Stop Switch

OPEN DELTA EXCITATION SYSTEM

This generator is equipped with the state of the art “**Open-Delta**” excitation system. The open delta system consist of an electrically independent winding wound among stationary windings of the AC output section.

There are four connections of the open delta A, B, C and D. During steady state loads, the power from the voltage regulator is supplied from the parallel connections of A to B, A to D, and C to D. These three phases of the voltage input to the voltage regulator are then rectified and are the excitation current for the exciter section.

When a heavy load, such as a motor starting or a short circuit occurs, the automatic voltage regulator (AVR) switches the configuration of the open delta to the series connection of B to C. This has the effect of adding the voltages of each phase to provide higher excitation to the exciter section and thus better voltage response during the application of heavy loads.

The connections of the AVR to the AC output windings are for sensing only. No power is required from these windings. The open-delta design provides virtually unlimited excitation current, offering maximum motor starting capabilities. The excitation does not have a “**fixed ceiling**” and responds according the demands of the required load.

ENGINE

This generator unit incorporates a Kubota V2403-CR-TIE4BG 4-cycle water cooled, direct injection turbocharged diesel engine. This engine is designed to meet every performance requirement for the generator. Reference Table 2 for engine specifications.

In keeping with MQ Power’s policy of constantly improving its products, the specifications quoted herein are subject to change without prior notice.

ELECTRIC GOVERNOR SYSTEM

The electric governor system controls the RPMs of the engine. When the engine demand increases or decreases, the governor system regulates the frequency variation to $\pm 0.25\%$.

MAJOR COMPONENTS

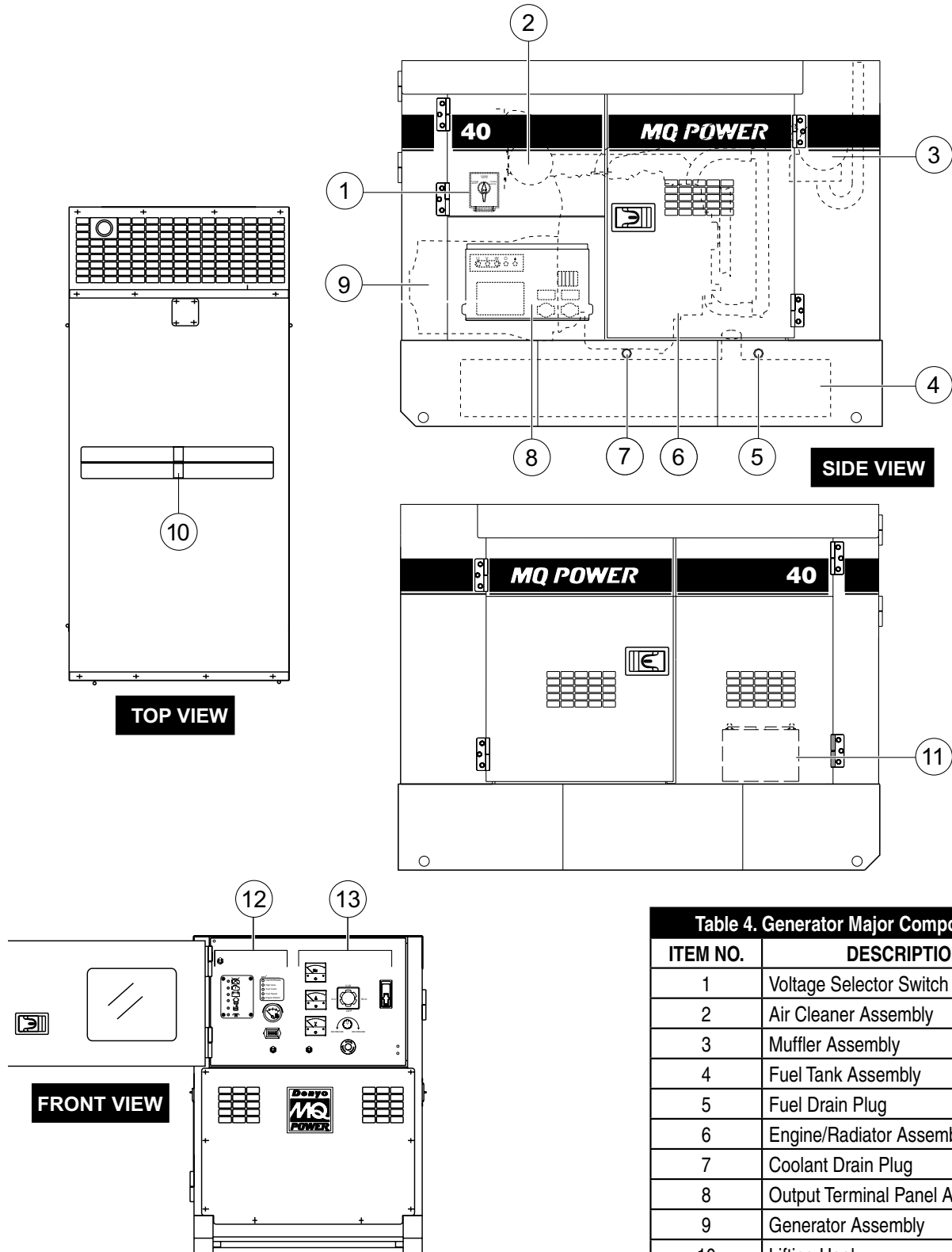

Figure 3. Major Components

Table 4. Generator Major Components	
ITEM NO.	DESCRIPTION
1	Voltage Selector Switch Assembly
2	Air Cleaner Assembly
3	Muffler Assembly
4	Fuel Tank Assembly
5	Fuel Drain Plug
6	Engine/Radiator Assembly
7	Coolant Drain Plug
8	Output Terminal Panel Assembly
9	Generator Assembly
10	Lifting Hook
11	Battery
12	Engine Control Panel Assembly
13	Generator Control Panel Assembly

ENGINE CONTROL PANEL

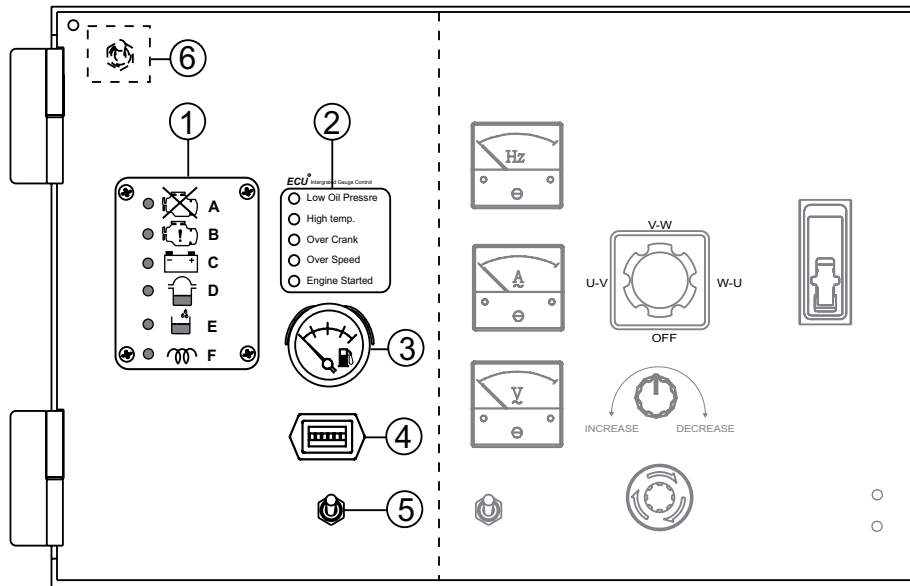

Figure 4. Engine Control Panel

The definitions below and on the preceding page describe the controls and functions of the Engine Control Panel (Figure 4).

1. **Engine Warning LEDs** — There are six engine warning lamps, they are defined as follows:
 - a. **Engine Shutdown** — Indicates that the engine has shutdown due to an engine failure LED will turn on.
 - b. **Engine Pre Alarm LED** — Indicates that an engine failure has occurred. LED will turn on or blink.
 - c. **Battery Charge Alarm LED** — This LED is **ON** when the output voltage of the alternator drops below a set value. If this lamp is ON during normal operation, the emergency shutdown system will immediately stop the engine.
 - d. **Fuel Filter Water Level LED** — This LED is **ON** when the water level in the fuel filter is extraordinary high.
 - e. **Fuel Leak Detected Lamp LED** — This LED is **ON** when the fluid in the containment is higher than allowable level.
 - f. **Pre-Heat LED** — The pre-heat LED will be **ON** during the pre-heating cycle (cold weather conditions). When the pre-heat cycle is completed the LED will turn **OFF** and the engine can be started.

ENGINE CONTROL PANEL

2. **Auto START/STOP Engine Controller (CAN 77)** — This controller has a vertical row of status LED's (inset), that when lit, indicate that an engine malfunction (fault) has been detected. When a fault has been detected the engine controller will evaluate the fault and all major faults will shutdown the generator. During cranking cycle, the ECU will attempt to crank the engine for 10 seconds before disengaging.

If the engine does not engage (start) by the third attempt, the engine will be shutdown by the engine controller's Over Crank Protection mode. If the engine engages at a speed (RPM's) that is not safe, the controller will shutdown the engine by initializing the Over Speed Protection mode.

Also the engine controller will shut down the engine in the event of low oil pressure, high coolant temperature, low coolant level, and loss of magnetic pickup. These conditions can be observed by monitoring the LED status indicators on the front of the controller module.

- A. **Low Oil Pressure** — Indicates the engine pressure has fallen below 14.2 psi (98 kPa). The oil pressure is detected using variable resistive values from the oil pressure sending unit. This is considered a major fault and the engine will be shut down.
- B. **High Coolant Temperature** — Indicates the engine temperature has exceeded 212° F (100° C). The engine temperature is detected using variable resistive values from the temperature sending unit. This is considered a major fault and the engine will be shut down.
- C. **Overcrank Shutdown** — Indicates the unit has attempted to start a pre- programmed number of times, and has failed to start. The number of cycles and duration are programmable. It is pre-set at 3 cycles with a 10 second duration. This is considered a major fault.
- D. **Overspeed Shutdown** — Indicates the engine is running at an unsafe speed. This is considered a major fault.
- E. **Engine Running** — Indicates that engine is running at a safe operating speed.

3. **Fuel Gauge** — Indicates amount of diesel fuel available.

4. **Hour Meter** — Indicates amount of time generator has been in use.

5. **Auto Start Stop Switch** — This switch controls the running of the unit. If this switch is set to the OFF/ RESET position, the unit will not run. When this switch is set to the manual position, the generator will start immediately.

If the generator is to be connected to a building's AC power source via an automatic transfer switch (isolation), place the switch in the AUTO position. In this position, should an outage occur, the automatic transfer switch (ATS) will start the generator automatically via the generator's auto-start contacts connected to the ATS's start contacts. Please refer to your ATS installation manual for further instructions for the correct installation of the auto-start contacts of the generator to the ATS.

6. **Diagnostic Switch** — When activated, fault errors in the engine or the engine control system will be displayed on the engine warning module (LED's).

GENERATOR CONTROL PANEL

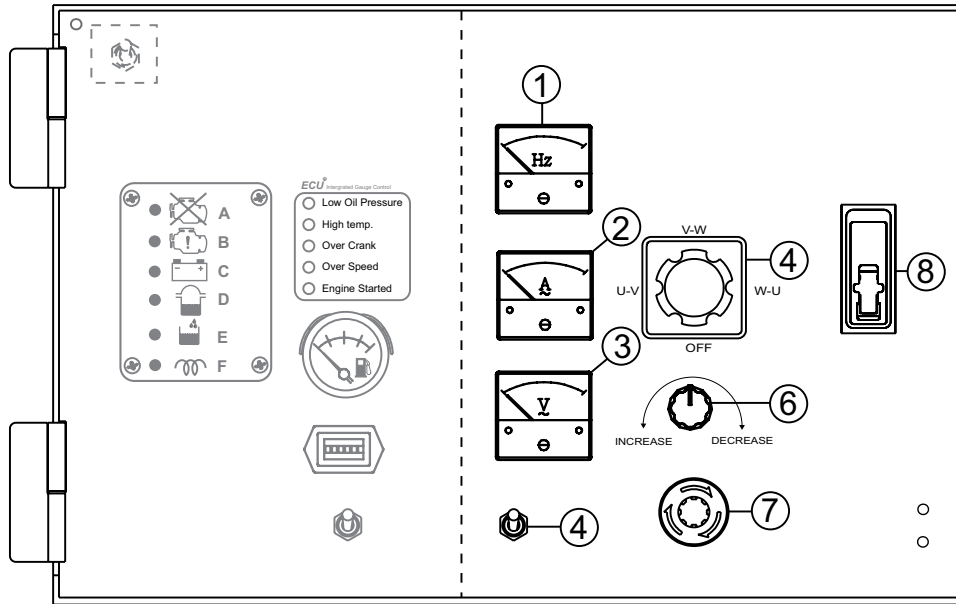

Figure 5. Generator Control Panel

The definitions below describe the controls and functions of the Generator Control Panel (Figure 5).

1. **Frequency Meter** — Indicates the output frequency in hertz (Hz). Normally 60 Hz.
2. **AC Ammeter** — Indicates the amount of current the load is drawing from the generator per leg selected by the ammeter phase-selector switch.
3. **AC Voltmeter** — Indicates the output voltage present at the U,V, and W output terminal lugs.
4. **Engine Speed Switch** — This switch controls the speed of the engine (low/high).
5. **Ammeter Change-Over Switch** — This switch allows the AC ammeter to indicate the current flowing to the load connected to any phase of the output terminals, or to be switched off. This switch does not effect the generator output in any fashion, it is for current reading only.
6. **Voltage Regulator Control** — Allows $\pm 15\%$ manual adjustment of the generator's output voltage.
7. **Emergency Stop Button (Option)** — Push this button inward to stop the engine in the event of an emergency. **DO NOT** use this button as a means of stopping the engine.
8. **Main Circuit Breaker** — This three-pole, 110A main breaker is provided to protect the the U,V, and W Output Terminal Lugs from overload.

NOTICE

Remember the **overcurrent relay** monitors the current flowing from the **U,V, and W output terminal lugs** to the load.

In the event of a short circuit or over current condition, it will automatically **trip** the 110 amp main breaker.

To restore power to the **output terminal panel**, press the reset button on the overcurrent relay and place the **main circuit breaker** in the **closed position (ON)**.

OUTPUT TERMINAL PANEL FAMILIARIZATION

OUTPUT TERMINAL PANEL

The Output Terminal Panel (Figure 6) shown below is located on the right-hand side (right from control panel) of the generator. Lift up on the cover to gain access to receptacles and terminal lugs.

NOTICE

Terminal legs "O" and "Ground" are considered bonded grounds.

OUTPUT TERMINAL FAMILIARIZATION

The "Output Terminal Panel" (Figure 6) is provided with the following:

- Two 120/240V output receptacles (CS6369) @ 50 amp
- Two Auxiliary Circuit Breakers @ 50 amps
- Two 120V GFCI receptacles @ 20 amp
- Two Duplex Circuit Breakers @ 20 amps
- Five Output Terminal Lugs (U, V, W, O, Ground)

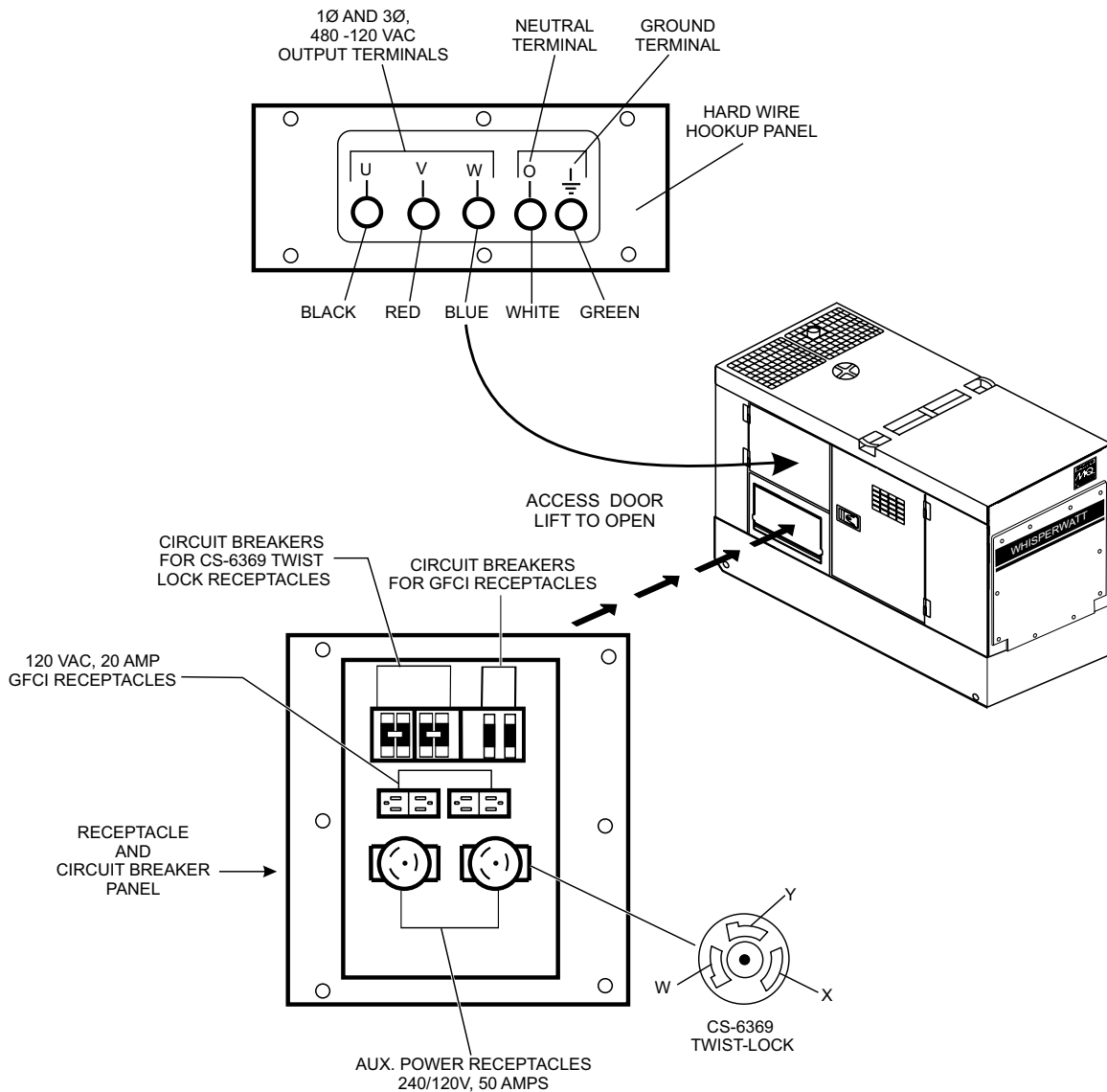

Figure 6. Output Terminal Panel

OUTPUT TERMINAL PANEL FAMILIARIZATION

120 VAC GFCI Receptacles

There are two 120 VAC, 20 amp GFCI (Duplex Nema 5-20R) receptacles provided on the output terminal panel. These receptacles can be accessed in **any voltage selector switch** position. Each receptacle is protected by a 20 amp circuit breaker. These breakers are located directly above the GFCI receptacles. Remember the load output (current) of both GFCI receptacles is dependent on the load requirements of the U, V, and W output terminal lugs.

Pressing the **reset** button resets the GFCI receptacle after being tripped. Pressing the **test** button (See Figure 7) in the center of the receptacle will check the GFCI function. Both receptacles should be tested at least once a month.

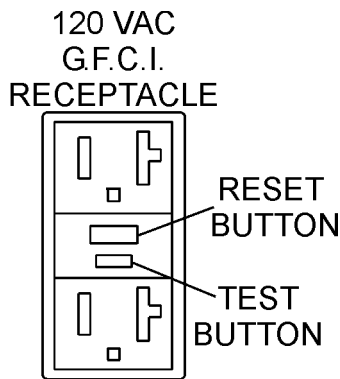

Figure 7. G.F.C.I. Receptacle

Twist Lock Dual Voltage 120/240 VAC Receptacles

There are two 240/120V, 50 amp auxiliary twist-lock (CS-6369) receptacles (Figure 8) provided on the output terminal panel. These receptacles can **only** be accessed when the voltage selector switch is placed in the **single-phase 240/120 position**.

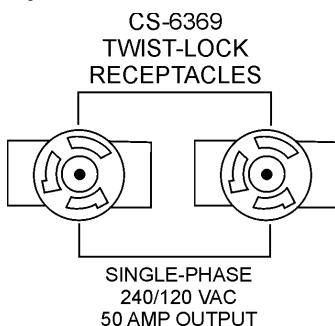

Figure 8. 240/120V Twist-Lock Auxiliary Receptacles

Each auxiliary receptacle is protected by a 50 amp circuit breaker. These breakers are located directly above the GFCI receptacles. Remember the load output (current) on both auxiliary receptacles is dependent on the load requirements of the **Output Terminal Lugs**.

Turn the **voltage regulator control knob** (Figure 9) on the control panel to obtain the desired voltage. Turning the knob clockwise will **increase** the voltage, turning the knob counter-clockwise will **decrease** the voltage.



Figure 9. Voltage Regulator Control Knob

Removing the Plastic Face Plate (Hard Wire Hookup Panel)

The **Output Terminal Lugs** are protected by a plastic face plate cover (Figure 10). Un-screw the securing bolts (2) and raise the plastic face plate to gain access to the output terminal lugs.

After the load wires have been securely attached to the output terminal lugs, lower the plastic face plate, and reinstall the retaining bolts.

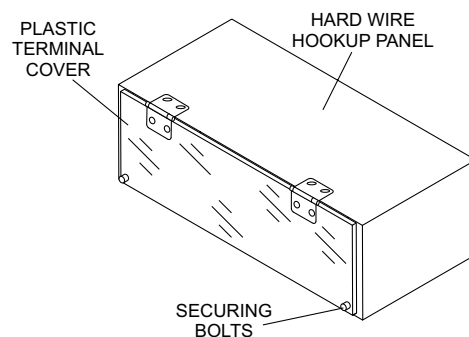

Figure 10. Plastic Face Plate (Output Terminal Lugs)

OUTPUT TERMINAL PANEL FAMILIARIZATION

Connecting Loads

NOTICE

When electric power is to be provided to various tools or loads at some distance from the generator, extension cords are normally used. Cables should be sized to allow for distance in length and amperage so that the voltage drop between the generator and point of use (load) is held to a minimum.

Use the cable selection chart (Table 6) as a guide for selecting proper extension cable size.

Loads can be connected to the generator by the **Output Terminal Lugs** or the convenience receptacles (Figure 11). Make sure to read the operation manual before attempting to connect a load to the generator.

To protect the output terminals from overload, a 3-pole, 110A **main** circuit breaker is provided. Make sure to switch **ALL** circuit breakers to the **OFF** position prior to starting the engine.

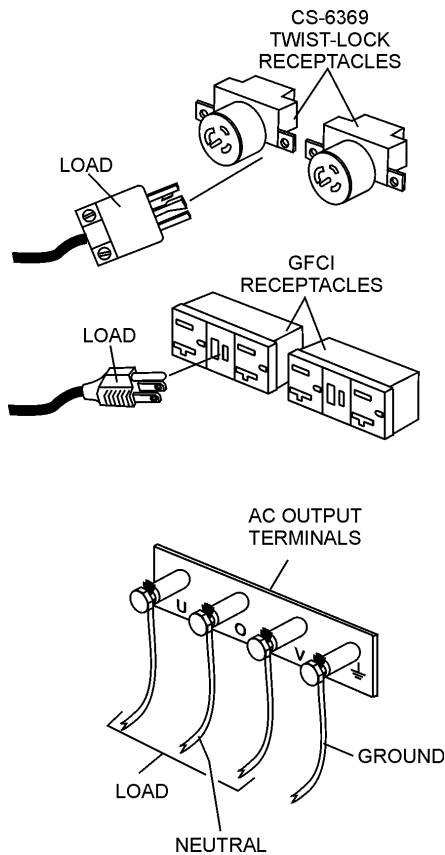

Figure 11. Connecting Loads

Over Current Relay

An **over current relay** (Figure 12) is connected to the main circuit breaker. In the event of an overload, both the circuit breaker and the over current relay may trip. If the circuit breaker can not be reset, the **reset button** on the over current relay must be pressed. The over current relay is located in the control box.

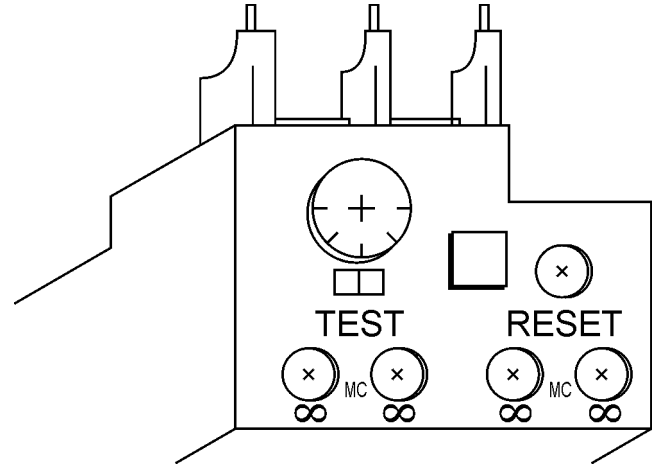

Figure 12. Over Current Relay

LOAD APPLICATION

SINGLE PHASE LOAD

Always be sure to check the nameplate on the generator and equipment to insure the wattage, amperage, frequency, and voltage requirements are satisfactorily supplied by the generator for operating the equipment.

Generally, the wattage listed on the nameplate of the equipment is its rated output. Equipment may require 130—150% more wattage than the rating on the nameplate, as the wattage is influenced by the efficiency, power factor and starting system of the equipment.

NOTICE

If wattage is not given on the equipment's name plate, approximate wattage may be determined by multiplying nameplate voltage by the nameplate amperage.

$$\text{WATTS} = \text{VOLTAGE} \times \text{AMPERAGE}$$

The power factor of this generator is 0.8. See Table 5 below when connecting loads.

Table 5. Power Factor By Load

Type of Load	Power Factor
Single-phase induction motors	0.4-0.75
Electric heaters, incandescent lamps	1.0
Fluorescent lamps, mercury lamps	0.4-0.9
Electronic devices, communication equipment	1.0
Common power tools	0.8

Table 6. Cable Selection (60 Hz, Single Phase Operation)

Current in Amperes	Load in Watts		Maximum Allowable Cable Length			
	At 100 Volts	At 200 Volts	#10 Wire	#12 Wire	#14 Wire	#16 Wire
2.5	300	600	1000 ft.	600 ft.	375 ft.	250 ft.
5	600	1200	500 ft.	300 ft.	200 ft.	125 ft.
7.5	900	1800	350 ft.	200 ft.	125 ft.	100 ft.
10	1200	2400	250 ft.	150 ft.	100 ft.	
15	1800	3600	150 ft.	100 ft.	65 ft.	
20	2400	4800	125 ft.	75 ft.	50 ft.	

CAUTION: Equipment damage can result from low voltage

THREE PHASE LOAD

When calculating the power requirements for 3-phase power use the following equation:

$$\text{KVA} = \frac{\text{VOLTAGE} \times \text{AMPERAGE} \times 1.732}{1000}$$

NOTICE

If 3Ø load (kVA) is not given on the equipment nameplate, approximate 3Ø load may be determined by multiplying voltage by amperage by 1.732.

NOTICE

Motors and motor-driven equipment draw much greater current for starting than during operation.

An inadequate size connecting cable which cannot carry the required load can cause a voltage drop which can burn out the appliance or tool and overheat the cable. See Table 6.

- When connecting a resistance load such as an incandescent lamp or electric heater, a capacity of up to the generating set's rated output (kW) can be used.
- When connecting a fluorescent or mercury lamp, a capacity of up to the generating set's rated output (kW) multiplied by 0.6 can be used.
- When connecting an electric drill or other power tools, pay close attention to the required starting current capacity.

When connecting ordinary power tools, a capacity of up to the generating set's rated output (kW) multiplied by 0.8 can be used.

DANGER

Before connecting this generator to any building's electrical system, a **licensed electrician** must install an **isolation (transfer) switch**. Serious damage to the building's electrical system may occur without this transfer switch.

GENERATOR OUTPUTS

GENERATOR OUTPUT VOLTAGES

A wide range of voltages are available to supply voltage for many different applications. Voltages are selected by using the **voltage selector** switch (Figure 13). To obtain some of the voltages as listed in Table 7 (see below) will require a fine adjustment using the **voltage regulator (VR) control knob** located on the control panel.

Voltage Selector Switch

The voltage selector switch (Figure 13) is located above the output terminal panel's Hard Wire Hook-up Panel. It has been provided for ease of voltage selection.

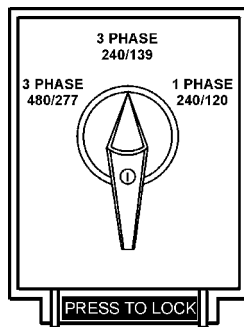

Figure 13. Voltage Selector Switch

Voltage Selector Switch Locking Button

To lock the voltage selector switch, **press and hold the red button** located at the bottom of the switch. While holding the red button down, insert a pad lock into the hole next to the button to retain it in the inward locked position. When the lock is removed, the red button is spring loaded and will return to its normal outward unlocked position.

CAUTION

NEVER change the position of the **voltage selector switch** while the engine is running. **ALWAYS** place circuit breaker in the **OFF** position before selecting voltage.

Table 7. Voltages Available

UVWO Output Terminal Lugs	Voltage Selector Switch 3-Phase 240/139V Position			Voltage Selector Switch 3-Phase 480/270V Position		
	3Ø Line-Line	208V	220V	240V	416V	440V
1Ø Line-Neutral	120V	127V	139V	240V	254V	277V
Voltage Selector Switch Single-Phase 240/120V Position						
1Ø Line-Neutral/ Line-Line	120V Line-Neutral	N/A	N/A	240V Line-Line	N/A	N/A

Generator Amperage

Table 8 shows the **maximum** amps the generator can provide. **DO NOT** exceed the maximum amps as listed..

Table 8. Generator Maximum Amps

Rated Voltage	Maximum Amps
1Ø 120 Volt	80 amps (4 wire) 108A x 2 (Zigzag)
1Ø 240 Volt	40 amps (4 wire) 108A (Zigzag)
3Ø 240 Volt	86 amps
3Ø 480 Volt	43 amps

GFCI Receptacle Load Capability

The load capability of the GFCI receptacles is directly related to the voltage being supplied at either the output terminals or the 2 twist lock auxiliary receptacles.

Table 9 and Table 10 show what amount of current is available at the GFCI receptacles when the output terminals and twist lock receptacles are in use. Be careful that your load does not to exceed the available current capability at the receptacles.

Table 9. 1Ø GFCI Receptacle Load Capacity

KW in Use Twist Lock (C6369)	Available Load Current (Amps)
1Ø 240/120V	GFCI Duplex 5-20R 120V
26.0	0
24.8	5 amps/receptacle
23.6	10 amps/receptacle
22.4	15 amps/receptacle
21.2	20 amps/receptacle

Table 10. 3Ø Generator Maximum Amps

KVA in Use (UVWO Terminals)	Available Load Current (Amps)
3Ø 240/480V	GFCI Duplex 5-20R 120V
36	0 amps/receptacle
31.8	5 amps/receptacle
27.7	10 amps/receptacle
23.5	15 amps/receptacle
19.4	20 amps/receptacle

GENERATOR OUTPUTS/GAUGE READING

HOW TO READ THE AC AMMETER AND AC VOLTAGE GAUGES

The AC ammeter and AC voltmeter gauges are controlled by the AC ammeter and AC voltmeter change-over switches.

Both of these switches are located on the control panel and **DO NOT** effect the generator output. They are provided to help observe how much power is being supplied, produced at the UVWO terminals lugs.

Before taking a reading from either gauge, set the **Voltage Selector Switch** (Figure 14) to the position which produces the required voltage (For example, for 3Ø 240V, choose the center 3Ø 240/139V position on the voltage selector switch).

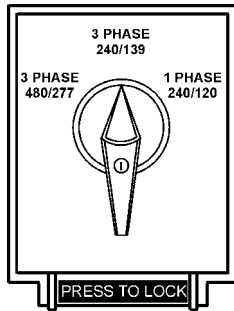

Figure 14. Voltage Selector Switch
240/139V 3Ø Position

NOTICE

For 3Ø 208V/1Ø,120V, place the Voltage Selector Switch in the 3 Phase 240/139 position.

AC Voltmeter Gauge Reading

Place the **AC Voltmeter Change-Over Switch** (Figure 15) in the W-U position and observe the phase voltage reading between the W and U terminals as indicated on the **AC Voltmeter Gauge** (Figure 16).

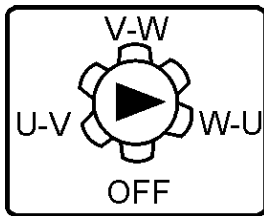

Figure 15. AC Voltmeter
Change-Over Switch

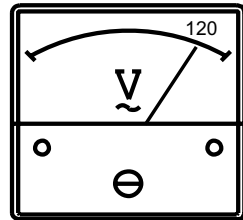

Figure 16. AC Voltmeter
Gauge

AC Ammeter Gauge Reading

Place the **AC Ammeter Change-Over Switch** (Figure 17) in the U position and observe the current reading (load drain) on the U terminal as indicated on the **AC Ammeter Gauge** (Figure 18). This process can be repeated for terminals V and W.

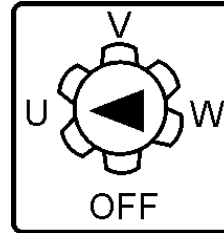

Figure 17. AC Ammeter
Change-Over Switch

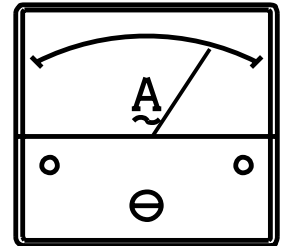

Figure 18. AC Ammeter
(Amp Reading on U Lug)

NOTICE

The **ammeter** gauge will only show a reading when the **Output Terminal Lugs** are connected to a load and in use.

OUTPUT TERMINAL PANEL CONNECTIONS

UVWO TERMINAL OUTPUT VOLTAGES

Various output voltages can be obtained using the UVWO output terminal lugs. The voltages at the terminals are dependent on the position of the **Voltage Selector Switch** and the adjustment of the **Voltage Regulator Control Knob**.

Remember the voltage selector switch determines the **range** of the output voltage. The voltage regulator (VR) allows the user to increase or decrease the selected voltage.

3Ø-240/139 UVWO Terminal Output Voltages

1. Place the voltage selector switch in the 3Ø 240/139 position as shown in Figure 19..

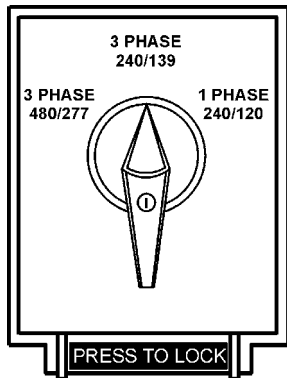

Figure 19. Voltage Selector Switch 3Ø-240/139V Position

2. Connect the load wires to the UVWO terminals as shown in Figure 20.

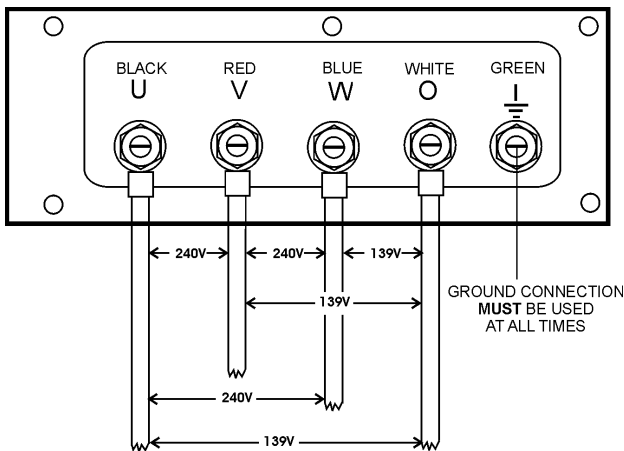

Figure 20. UVWO Terminal Lugs 3Ø-240/139V Connections

3. Turn the voltage regulator knob (Figure 21) clockwise to increase voltage output, turn counterclockwise to decrease voltage output. Use voltage regulator adjustment knob whenever fine tuning of the output voltage is required.



Figure 21. Voltage Regulator Knob

3Ø-208V/1Ø-120V UVWO Terminal Output Voltages

1. Place the voltage selector switch in the 3Ø 240/139 position as shown in Figure 22.

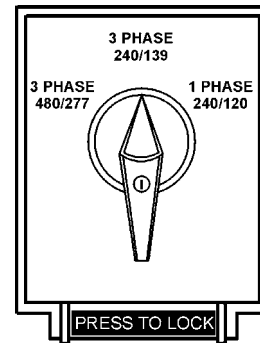

Figure 22. Voltage Selector Switch 3Ø-240/139V Position

2. Connect the load wires to the UVWO terminals as shown in Figure 23.

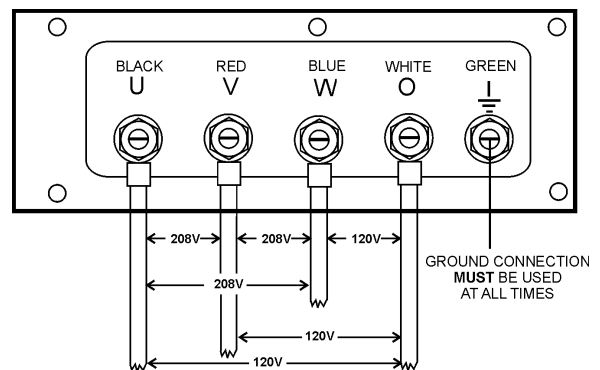

Figure 23. UVWO Terminal Lugs 3Ø-208V/1Ø-120V Connections

NOTICE

To achieve a 3Ø 208V output the voltage selector switch must be in the 3Ø-240/139 position and the voltage regulator must be adjusted to 208V..

OUTPUT TERMINAL PANEL CONNECTIONS

3Ø-480/277V UVWO Terminal Output Voltages

1. Place the voltage selector switch in the 3Ø 480/277 position as shown in Figure 24.

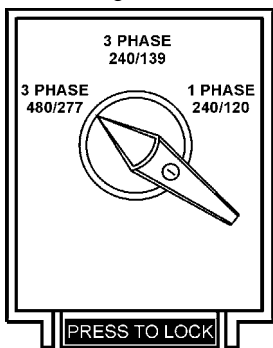

**Figure 24. Voltage Selector Switch
3Ø-480/277V Position**

2. Connect the load wires to the UVWO terminals as shown in Figure 25.

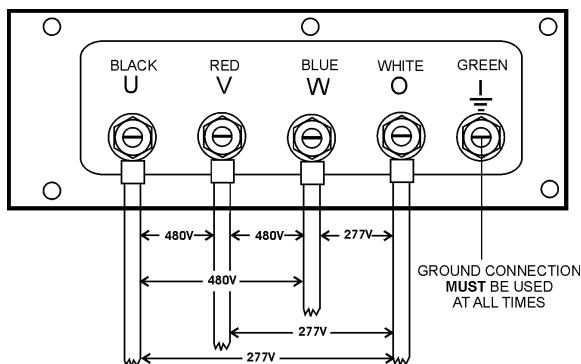
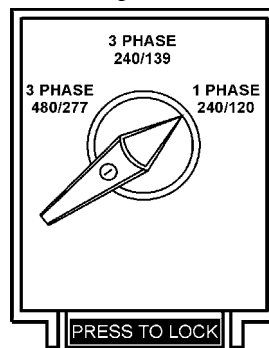

**Figure 25. UVWO Terminal Lugs
3Ø-440/254V Connections**

3. Turn the voltage regulator knob (Figure 21) clockwise to increase voltage output, turn counterclockwise to decrease voltage output. Use voltage regulator adjustment knob whenever fine tuning of the output voltage is required.

1Ø-240/120V UVWO Terminal Output Voltages

1. Place the voltage selector switch in the 1Ø 240/120 position as shown in Figure 26.



**Figure 26. Voltage Selector Switch
1Ø-240/120V Position**

2. Connect the load wires to the UVWO terminals as shown in Figure 27.

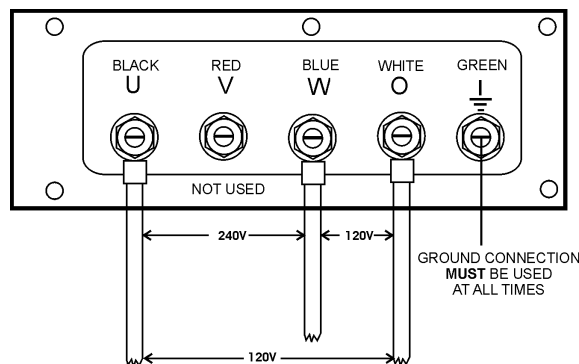

**Figure 27. UVWO Terminal Lugs
1Ø-200/100V Connections**

3. Turn the voltage regulator knob (Figure 21) clockwise to increase voltage output, turn counterclockwise to decrease voltage output. Use voltage regulator adjustment knob whenever fine tuning of the output voltage is required.

NOTICE

ALWAYS make sure that the connections to the UVWO terminals are **secure** and **tight**. The possibility of arcing exists, that could cause a fire.

CIRCUIT BREAKERS

To protect the generator from an overload, a 3-pole, 110 amp, main circuit breaker is provided to protect the **U, V, and W output terminals** from overload. In addition two single-pole, 20 amp **duplex** circuit breakers are provided to protect the GFCI receptacles from overload. Two 50 amp circuit breakers have also been provided to protect the auxiliary receptacles from overload. Make sure to switch **ALL** circuit breakers to the **OFF** position prior to starting the engine.

LUBRICATION OIL

Fill the engine crankcase with lubricating oil through the filler hole, but **DO NOT** overfill. Make sure the generator is level and verify that the oil level is maintained between the two notches (Figure 28) on the dipstick. See Table 11 for proper selection of engine oil.

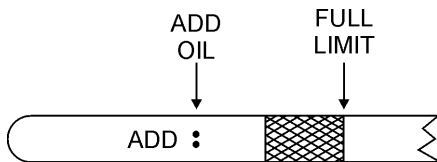

Figure 28. Engine Oil Dipstick

When checking the engine oil, be sure to check if the oil is clean. If the oil is not clean, drain the oil by removing the oil drain plug, and refill with the specified amount of oil as outlined in the **KUBOTA Engine Owner's Manual**. Oil should be warm before draining.

Other types of motor oils may be substituted if they meet the following requirements:

- API Service Classification CC/SC
- API Service Classification CC/SD
- API Service Classification CC/SE
- API Service Classification CC/SF

Table 11. Recommended Motor Oil		OIL: SAE	
°F	°C	SAE	SAE
122	50	10W/40	10W/40
104	40	10W/40	30
86	30	10W/40	10W/40
68	20	15W/30	15W/30
50	10	10W/30	10W/30
32	0	10W/30	10W
-14	-10	5W/30	20W/40
-4	-20	ARCTIC OIL	
-22	-30		
-40	-40		

FUEL CHECK

! DANGER

Fuel spillage on a **hot** engine can cause a **fire** or **explosion**. If fuel spillage occurs, wipe up the spilled fuel completely to prevent fire hazards. **NEVER** smoke around or near the generator.

Refilling the Fuel System

! CAUTION

ONLY properly trained personnel who have read and understand this section should refill the fuel tank system.

This generator has an internal fuel tank located inside the generator enclosure frame and may also be equipped with an environmental fuel tank (Figure 29). **ALWAYS** fill the fuel tanks with clean fresh **#2 diesel fuel**. **DO NOT** fill the fuel tanks beyond their capacities.

Pay attention to the fuel tank capacity when replenishing fuel. The fuel tank cap must be closed tightly after filling. Handle fuel in a safety container. If the container does not have a spout, use a funnel. Wipe up any spilled fuel immediately.

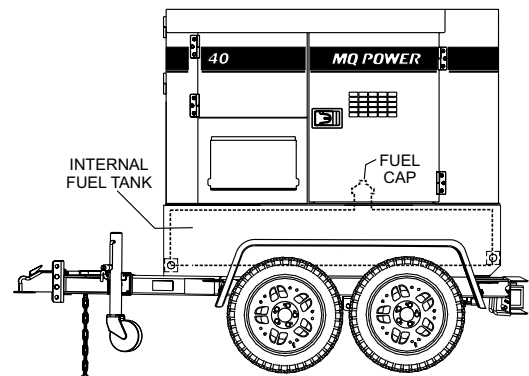

Figure 29. Internal Fuel Tank System

INSPECTION/SETUP

Refueling Procedure:

WARNING



Diesel fuel and its vapors are dangerous to your health and the surrounding environment. Avoid skin contact and/or inhaling fumes.

1. **Level Tanks** — Make sure fuel cells are level with the ground. Failure to do so will cause fuel to spill from the tank before reaching full capacity (Figure 30).

CAUTION

ALWAYS place trailer on firm level ground before refueling to prevent spilling and maximize the amount of fuel that can be pumped into the tank.

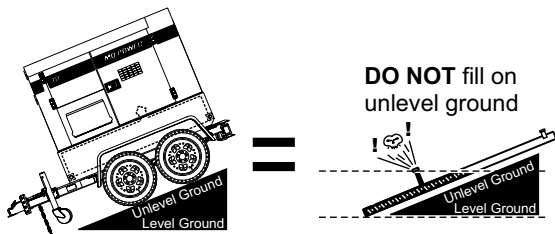

Figure 30. Only Fill on Level Ground

NOTICE

ONLY use *low sulfur* or *ultra low sulfur* diesel fuel when refueling.

2. Open cabinet doors on the “right side” of the generator (from generator control panel position). Remove fuel cap and fill tank as shown in Figure 31.

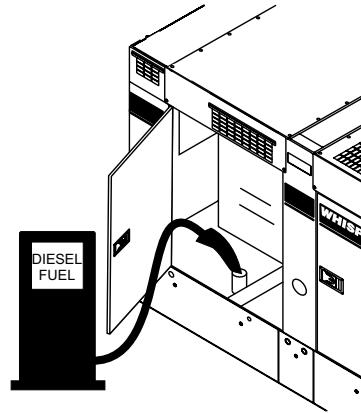

Figure 31. Fueling the Generator

3. **NEVER overfill fuel tank** — It is important to read the fuel gauge when filling trailer fuel tank. **DO NOT** wait for fuel to rise in filler neck (Figure 32).

FUEL GAUGE LOCATED ON CONTROL PANEL

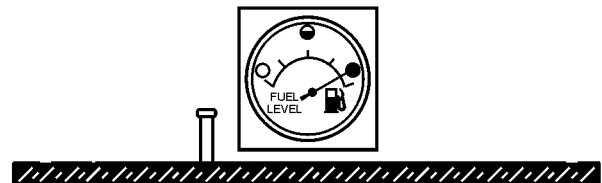

Figure 32. Full Fuel Tank

CAUTION

DO NOT OVERFILL fuel system. Leave room for fuel expansion. Fuel expands when heated (Figure 33).



Figure 33. Fuel Expansion

COOLANT (ANTIFREEZE/SUMMER COOLANT/WATER)

KUBOTA recommends antifreeze/summer coolant for use in their engines, which can be purchased in concentrate (and mixed with 50% demineralized water) or pre-diluted. See the **KUBOTA Engine Owner's Manual** for further details.

WARNING



If adding coolant/antifreeze mix to the radiator, **DO NOT** remove the radiator cap until the unit has completely cooled. The possibility of **hot!** coolant exists which can cause severe burns.

Day-to-day addition of coolant is done from the recovery tank. When adding coolant to the radiator, **DO NOT** remove the radiator cap until the unit has completely cooled. See Table 12 for engine, radiator, and recovery tank coolant capacities. Make sure the coolant level in the recovery tank is always between the “H” and the “L” markings.

Engine and Radiator	4.75 gal (18 liters)
Reserve Tank	N/A

Operation in Freezing Weather

When operating in freezing weather, be certain the proper amount of antifreeze (Table 13) has been added.

Vol % Anti-Freeze	Freezing Point		Boiling Point	
	°C	°F	°C	°F
50	-37	-34	108	226

NOTICE

When the antifreeze is mixed with water, the antifreeze mixing ratio **must be** less than 50%.

CLEANING THE RADIATOR

The engine may overheat if the radiator fins become overloaded with dust or debris. Periodically clean the radiator fins with compressed air. Cleaning inside the machine is dangerous, so clean only with the engine turned off and the **negative** battery terminal disconnected.

AIR CLEANER

Periodic cleaning/replacement is necessary. Inspect it in accordance with the **KUBOTA Engine Owner's Manual**.

FAN BELT TENSION

A slack fan belt may contribute to overheating, or to insufficient charging of the battery. Inspect the fan belt for damage and wear and adjust it in accordance with the **KUBOTA Engine Owner's Manual**.

The fan belt tension is proper if the fan belt bends 10 to 15 mm (Figure 34) when depressed with the thumb as shown below.

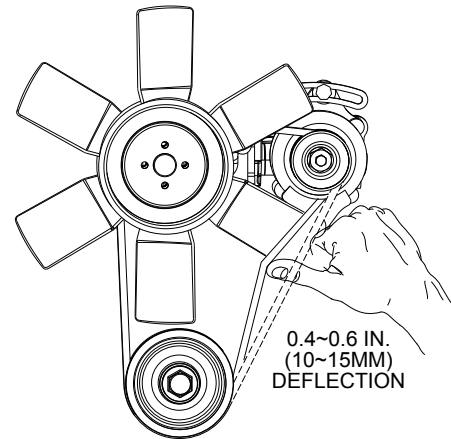



Figure 34. Fan Belt Tension

CAUTION



NEVER place hands near the belts or fan while the generator set is running.

BATTERY

This unit is of negative ground **DO NOT** connect in reverse. Always maintain battery fluid level between the specified marks. Battery life will be shortened, if the fluid level are not properly maintained. Add only distilled water when replenishment is necessary.

DO NOT over fill. Check to see whether the battery cables are loose. Poor contact may result in poor starting or malfunctions. **Always** keep the terminals firmly tightened. Coating the terminals with an approved battery terminal treatment compound. Replace battery with only recommended type battery.

The battery is sufficiently charged if the specific gravity of the battery fluid is 1.28 (at 68° F). If the specific gravity should fall to 1.245 or lower, it indicates that the battery is dead and needs to be recharged or replaced.

Before charging the battery with an external electric source, be sure to disconnect the battery cables.

Battery Cable Installation

ALWAYS be sure the battery cables (Figure 35) are properly connected to the battery terminals as shown below. The **red cable** is connected to the positive terminal of the battery, and the **black cable** is connected to the negative terminal of the battery.

CAUTION

ALWAYS disconnect the negative terminal **FIRST** and reconnect negative terminal **LAST**.

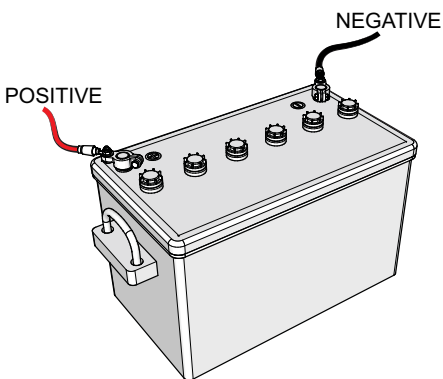

Figure 35. Battery Connections

When connecting battery do the following:

1. **NEVER** connect the battery cables to the battery terminals when the **MPEC Control Switch** is in either the **MANUAL** position. **ALWAYS** make sure that the **MPEC Control Switch** is in the **OFF/RESET** position when connecting the battery.
2. Place a small amount of battery terminal treatment compound around both battery terminals. This will ensure a good connection and will help prevent corrosion around the battery terminals.

NOTICE

If the battery cable is connected incorrectly, electrical damage to the generator will occur. Pay close attention to the polarity of the battery when connecting the battery.

CAUTION

Inadequate battery connections may cause poor starting of the generator, and create other malfunctions.

ALTERNATOR

The polarity of the alternator is negative grounding type. When an inverted circuit connection takes place, the circuit will be in short circuit instantaneously resulting the alternator failure.

DO NOT put water directly on the alternator. Entry of water into the alternator can cause corrosion and damage the alternator.

WIRING

Inspect the entire generator for bad or worn electrical wiring or connections. If any wiring or connections are exposed (insulation missing) replace wiring immediately.

PIPING AND HOSE CONNECTION

Inspect all piping, oil hose, and fuel hose connections for wear and tightness. Tighten all hose clamps and check hoses for leaks.

If any hose (**fuel or oil**) lines are defective replace them immediately.

GENERATOR START-UP PROCEDURE (MANUAL)

BEFORE STARTING

CAUTION

The engine's exhaust contains harmful emissions. **ALWAYS** have adequate ventilation when operating. Direct exhaust away from nearby personnel.

WARNING

NEVER manually start the engine with the **main, duplex or auxiliary** circuit breakers in the **ON** (closed) position.

- Place the **Main, Aux.** and **Duplex** circuit breakers (Figure 36) in the **OFF** position prior to starting the engine.

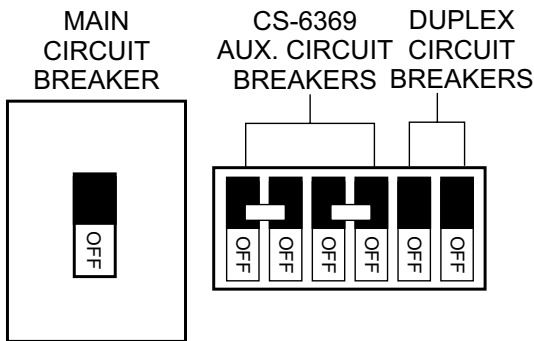

Figure 36. Main, Aux. and Duplex Circuit Breakers (OFF)

- Connect the load to the **receptacles** or the **output terminal lugs** as shown in Figure 11. These load connection points can be found on the output terminal panel and the output terminal panel's hard wire hookup panel.
- Tighten terminal nuts securely to prevent load wires from slipping out.
- Close all engine enclosure doors (Figure 37).

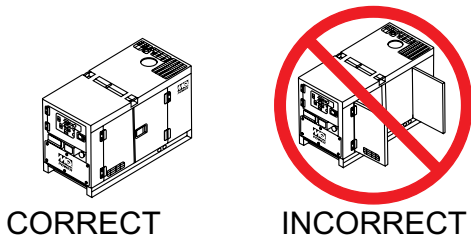

Figure 37. Engine Enclosure Doors

STARTING (MANUAL)

- Place the **voltage selector switch** in the desired voltage position (Figure 38).

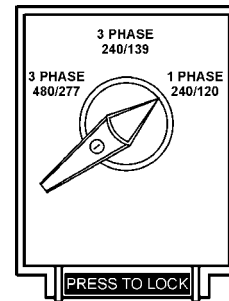

Figure 38. Voltage Selector Switch

- Place the engine speed switch (Figure 39) in the **LOW** (down) position



Figure 39. Engine Speed Switch (Low)

- Place the **Auto-Off/Reset Manual Switch** in the **MANUAL** position to start the engine (Figure 40).

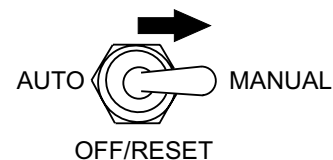

Figure 40. Auto-Off/Reset Manual Switch (Manual Position)

- Depending on the temperature of the coolant (cold weather conditions), the pre-heat LED (Figure 41) will light **(ON)** and remain on until the pre-heating cycle has been completed. After completion of the pre-heating cycle, the LED will go **OFF** and the engine will start.

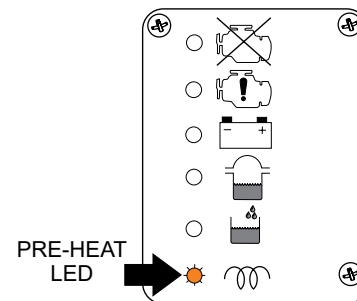

Figure 41. Pre-Heat LED Engine Warning Unit

GENERATOR START-UP PROCEDURE (MANUAL)

NOTICE

In **cold** weather conditions warm up the engine 5-7 minutes before placing into operation.

- In **warm** weather conditions let the engine run for 1-2 minutes. Listen for any abnormal noises. If any abnormalities exist, shut down the engine and correct the problem.
- Verify that the engine started status LED on the ECU controller is on (Figure 42).

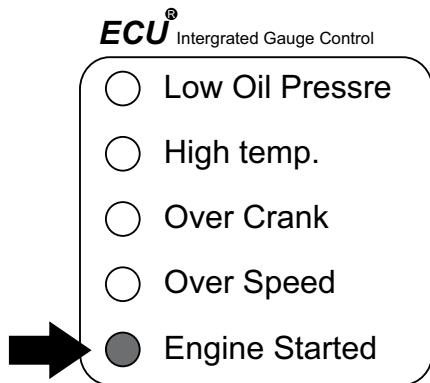

Figure 42. ECU Controller (Engine Started LED)

NOTICE

If the engine fails to start after 3 attempts, the over-crank LED on the ECU controller will turn on and the Auto-Off/Reset Switch must be placed in the Off/Reset position before the engine can be restarted.

- If the engine is running smoothly, place the engine speed switch (Figure 43) in the **HIGH** (up) position).



Figure 43. Engine Speed Switch (High)

- The generator's **frequency meter** (Figure 44) should be displaying the 60 cycle output frequency in **HERTZ**.

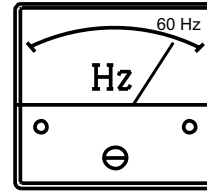

Figure 44. Frequency Meter

- The generator's **AC-voltmeter** (Figure 45) will display the generator's output in **VOLTS**.

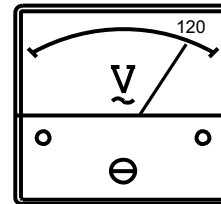

Figure 45. Voltmeter Meter

- If the voltage is not within the specified tolerance use the voltage adjustment control knob (Figure 46) to increase or decrease the desired voltage.



Figure 46. Voltage Adjust Control Knob

- The ammeter (Figure 47) will indicate **zero amps** with no load applied. When a load is applied, the ammeter will indicate the amount of current that the load is drawing from the generator.

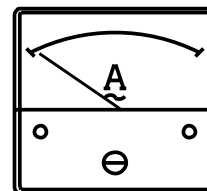

Figure 47. Ammeter (No Load)

GENERATOR START-UP PROCEDURE (MANUAL)

12. Place the **Main, Aux.** and **Duplex** circuit breakers in the **ON** position (Figure 48).

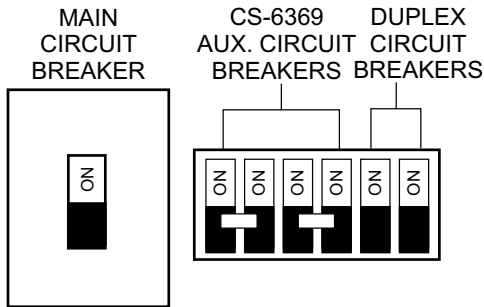

Figure 48. Main, Aux. and Duplex Circuit Breakers (ON)

13. Observe the generator's ammeter (Figure 49) and verify it reads the anticipated amount of current with respect to the load. The ammeter will only display a current reading if a load is in use.

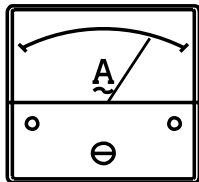

Figure 49. Ammeter (Load)

14. The generator will run until manually stopped or an abnormal condition occurs.

GENERATOR START-UP PROCEDURE (AUTO)

DANGER



Before connecting this generator to any building's electrical system, a **licensed electrician** must install an **isolation (transfer) switch**. Serious damage to the building's electrical system may occur without this transfer switch.

NOTICE

When connecting the generator to a isolation (transfer) switch, **ALWAYS** have power applied to the generator's internal battery charger. This will ensure that the engine will not fail due to a dead battery.

NOTICE

When the **Auto Off/Reset Manual** switch is placed in the **AUTO** mode, the generator will **automatically start** in the event of commercial power falling below a prescribed level by means of a contact closure that is generated automatically by a transfer switch.

In this position (**AUTO**), should an outage occur, the automatic transfer switch (ATS) will start the generator automatically via the generator's auto-start contacts connected to the ATS's start contacts.

Please refer to your ATS installation manual for further instructions for the correct installation of the auto-start contacts of the generator to the ATS.

WARNING

When running the generator in the **AUTO** mode, remember the generator can start up at any time without warning. **NEVER** attempt to perform any maintenance when the generator is in the auto mode.

NOTICE

When the **Auto Off/Reset Manual** switch is placed in the **AUTO** position, the engine glow plugs will be warmed and the engine will start automatically.

NOTICE

The engine speed switch **must** be set to the "High" position when running in the **auto-start** mode. Failing to set the switch in the proper position can result in damage to your generator when it turns on.

STARTING (AUTO MODE)

When starting generator in **AUTO** mode use the "Manual Start-up" procedure except where noted (see below).

1. Perform steps 1 through 5 in the Before Starting section as outlined in the Manual Starting Procedure.
2. Place the **Auto Off/Reset Manual Switch** (Figure 50) in the **AUTO** position.



Figure 50. Auto Off/Reset Manual Switch (AUTO)

3. Continue operating the generator as outlined in the Manual Start-up procedure (start at step 8).

GENERATOR SHUT-DOWN PROCEDURES

NORMAL SHUTDOWN PROCEDURE

NOTICE

NEVER stop the engine suddenly except in an emergency.

To shutdown the generator, use the following procedure:

1. Place the **Main**, **Aux.** and **Duplex** circuit breakers (Figure 51) in the **OFF** position.

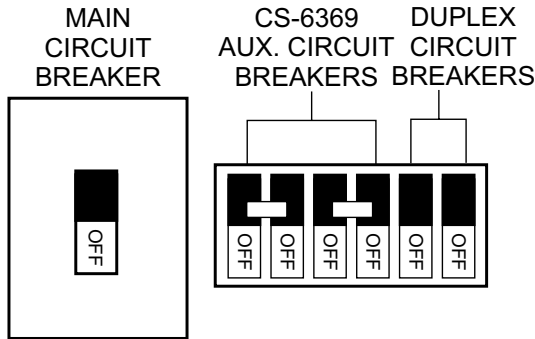

Figure 51. Main, Aux. and Duplex Circuit Breakers (OFF)

2. Place the engine speed control switch (Figure 52) in the Start/Idle position (down).



Figure 52. Engine Speed Switch Start/Idle Position

3. Let the engine cool by running it at low speed for 3-5 minutes with no load applied.
4. Place the **Auto-Off/Reset Manual Switch** in the **OFF/Reset** position () to start the engine.



Figure 53. Auto-Off/Reset Manual Switch (Off/Reset Position)

5. Remove all loads from the generator.
6. Inspect entire generator for any damage or loosening of components that may have occurred during operation.

EMERGENCY SHUTDOWN PROCEDURE

1. If equipped (option), push the **Emergency Stop Pushbutton Switch** (Figure 54).

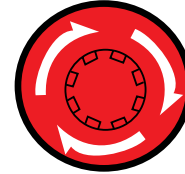

Figure 54. Emergency Stop Button

2. If unit is not equipped with an emergency stop switch, place the **Auto Off/Reset Manual Switch** (Figure 50) in the **Off/Reset** position.

AUTOMATIC SHUT-DOWN SYSTEM

This unit is equipped with safety devices to automatically stop the engine in the event of low oil pressure, approximately 14.2 psi (96.5 kPa), or high water temperature, approximately 212° F (100° C). The LED alarm indicators on the Engine Control Unit (ECU) illuminate to signify the reason for the shutdown.

NOTICE

Before inspecting, place all circuit breakers in the **OFF** position and allow sufficient time for adequate cooling. When ready to restart, complete all steps in the Generator Startup Procedure section of this manual.

MAINTENANCE

Table 14. Inspection/Maintenance		10 Hrs DAILY	250 Hrs	500 Hrs or Every 12 Months	3000 Hrs or Every 36 Months	OTHER
Engine	Check Engine Oil and Coolant Levels	X				
	Check Fuel Filter/Water Separator Bowl	X				
	Check Air Cleaner	X				
	Check Air Cleaner Element	X				
	Check for Leaks/Hoses/Clamps	X				
	Check for Loosening of Parts	X				
	Change Engine Oil and Oil Filter * 1		X			
	Clean Unit, Inside and Outside		X			
	Replace Fuel Filter Elements			X		
	Check Engine Mounts			X		
	Service Battery			X		
	Check Air Intake Hoses			X		
	Check Fan Belt Condition			X		
	Check Automatic Belt Tensioner			X		
	Check Electrical Ground Connection			X		
	Clean Radiator, Check Cooling System			X		
	Coolant Solution Analysis, Add SCA's As Required			X		
	Pressure Test Cooling System			X		
	Check Engine Speed			X		
	Test Thermostat					6000 hrs.
	Check and Adjust Engine Valve Clearance				X	
	Test Glow Plugs				X	
	Replace Diesel Oxidation Catalyst (DOC) * 2					4500 hrs.
Flush and Refill Cooling System					2 yrs. or 2000 hrs.	
Clean Inside of Fuel Tank					1000 hrs.	
Check Crankcase Ventilation Filter				X		
Replace Air Cleaner Elements * 3					As Required	
Generator	Measure Insulation Resistance Over 3M ohms		X			
	Check Rotor Rear Support Bearing			X		s

*1 During initial operation of a new engine, change oil and filter between a minimum of 100 hrs. and a maximum of 500 hrs. Service interval depends on type of oil.

*2 Expectation for minimal service interval will be at least 4500 hrs. based on engine power. However, actual service should take place when indicated by diagnostic gauge. Please contact nearest authorized Multiquip Service Center for DOC Cleaning.

*3 Replace primary air filter element when restriction indicator shows a vacuum of 625 mm (25 in. H₂O).

GENERAL INSPECTION

Prior to each use, the generator should be cleaned and inspected for deficiencies. Check for loose, missing or damaged nuts, bolts or other fasteners. Also check for fuel, oil, and coolant leaks. Use Table 14 as a general maintenance guideline **Engine Side** (Refer to the Engine Instruction Manual).

AIR CLEANER

NOTICE

If the engine is operating in very **dusty** or **dry** grass conditions, a clogged air cleaner will result. This can lead to a loss of power, excessive carbon buildup in the combustion chamber and high fuel consumption. Change air cleaner more **frequently** if these conditions exist.

Every 250 hours: Remove air cleaner element (Figure 55) and clean the heavy duty paper element with light spray of compressed air. Replace the air cleaner as needed.

This Kubota diesel engine is equipped with a replaceable, high-density paper air cleaner element. This air cleaner is also equipped with an inner element (secondary) that is used as a backup filter should the primary element becomes damaged.

CAUTION



Wear protective equipment such as approved safety glasses or face shields and dust masks or respirators when cleaning air filters with compressed air.

Primary and Secondary Air Cleaner Elements

1. Release the latches (Figure 55) that secures the cover to the air cleaner body.
2. Remove the air cleaner cover and set aside.
3. Remove both the primary and secondary air cleaner elements.
4. Check the air cleaner daily or before starting the engine
5. Check for and correct heavy buildup of dirt and debris along with loose or damaged components.

NOTICE

Operating the engine with loose or damaged air cleaner components could allow unfiltered air into the engine causing premature wear and failure.

6. To clean the primary element (paper air filter) as referenced in (Figure 55), tap the filter element several times on a hard surface to remove dirt, or blow compressed air (not to exceed 30 psi (207 kPa, 2.1 kgf/cm²) through the filter element from the inside out.

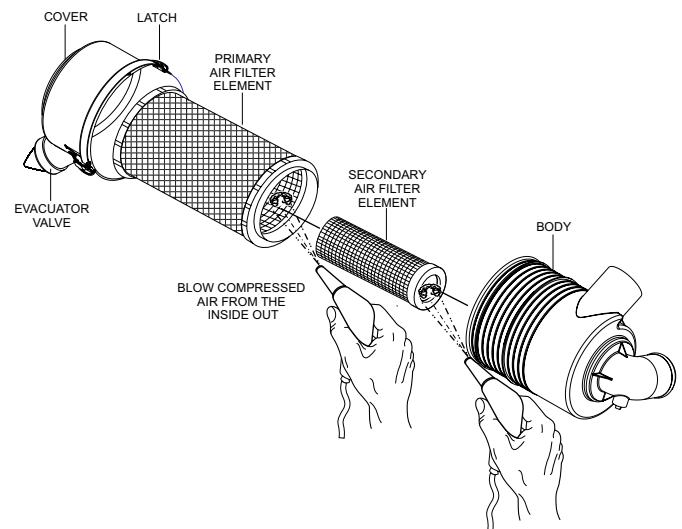

Figure 55. Air Cleaner

7. Clean the secondary element (paper air filter) as referenced in step 6.
8. Replace both elements if they are damaged or excessively dirty.
9. Clean the inside of the air cleaner body.
10. Reinstall the primary and secondary air filter elements back into air cleaner body.
11. Reinstall the air cleaner cover, and secure with latches.

ENGINE FUEL FILTER REPLACEMENT

1. Clean the area around the lubricating fuel filter head.
2. Using an oil filter wrench (Figure 56), remove fuel filter.

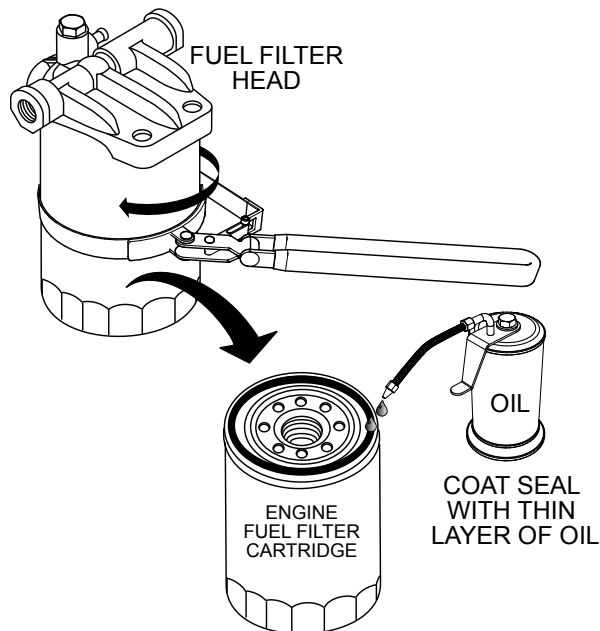

Figure 56. Fuel Filter Removal

3. Coat the rubber seal (gasket) surface of the fuel filter with clean 15W-40 engine oil.
4. Install new oil filter first by hand until it makes contacts with the filter head surface. Tighten it another 3/4 turn using the filter wrench.

FUEL FILTER/WATER SEPARATOR

Inspect the fuel filter water separator daily. If the fuel filter/water separator (Figure 57) has collected a significant amount of water and sediment at the bottom of the cup (indicator mark), it should be drained off.

Draining Of Fuel Water Separator

NOTICE

As water is collected, the red float goes up. When the float has reached the indicator mark (Figure 57), immediately drain the fuel water separator.

1. Place the Open/Close fuel valve lever (Figure 57) in the **CLOSED** position.

2. Loosen the screw at the top of the filter head and also loosen the drain cock located at the bottom of the filter.
3. Let the residue or foreign substances inside the cup flow into a suitable container.
4. Tighten screw and place fuel valve lever in the **OPEN** position.

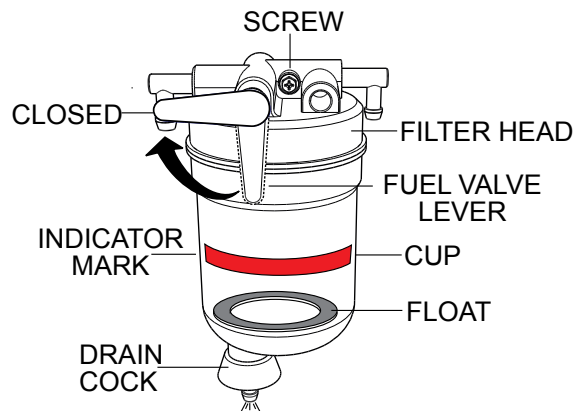

Figure 57. Fuel Filter/Water Separator

Cleaning Fuel Water Separator

NOTICE

If air enters the fuel injection system of a diesel engine, starting becomes impossible. After running out of fuel, or after disassembling the fuel system, air-bleed the fuel system in accordance with the **KUBOTA Engine Service Manual**.

To restart engine after running out of fuel, place the **Auto-Off/Reset Manual Switch** in the **MANUAL** position. Try again, if needed.

1. Place the fuel valve lever in the **CLOSED** position.
2. Remove cup from filter head assembly.
3. Clean inside of cup with a light oil.
4. Clean the area around the fuel filter water separator head.
5. Reattach cup to filter head assembly.
6. Place the fuel valve lever in the **OPEN** position.
7. Air-bleed fuel system before starting engine.

Removing Water from the Fuel Tank

After prolonged use, water and other impurities accumulate in the bottom of the tank. Occasionally inspect the fuel tank for water contamination and drain the contents if required.

During cold weather, the more empty volume inside the tank, the easier it is for water to condense. This can be reduced by keeping the tank full with diesel fuel.

Cleaning Inside the Fuel Tank

If necessary, drain the fuel inside the fuel tank completely. Using a spray washer (Figure 58) wash out any deposits or debris that have accumulated inside the fuel tank.

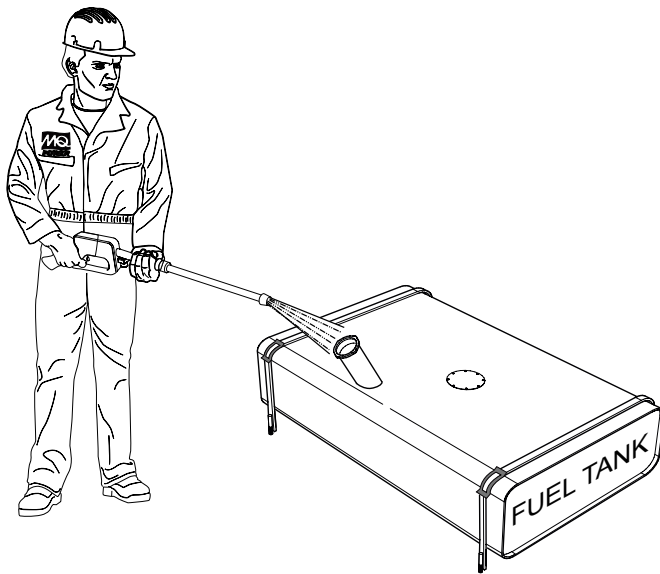

Figure 58. Fuel Tank Cleaning

FUEL TANK INSPECTION

In addition to cleaning the fuel tank, the following components should be inspected for wear:

- **Rubber Suspension** — look for signs of wear or deformity due to contact with oil. Replace the rubber suspension if necessary.
- **Fuel Hoses** — inspect nylon and rubber hoses for signs of wear, deterioration and hardening.
- **Fuel Tank Lining** — inspect the fuel tank lining for signs of excessive amounts of oil or other foreign matter.

Loosen the drain plug at the lower top of the fuel filter. Drain the fuel in the fuel body together with the mixed.

V-BELT (DAILY)

Visually examine the V-belt (Figure 59) and determine if it is full of tiny cracks, frayed, has pieces of rubber missing, is peeling, or is otherwise damaged.

Also, examine the belt and determine if it is **oil soaked** or **"glazed"** (hard shiny appearance on the sides of the belt). Either of these two conditions can cause the belt to run hot, which can weaken it and increase the danger of it breaking.

If the V-belt exhibits any of the above wear conditions, replace the V-belt immediately.

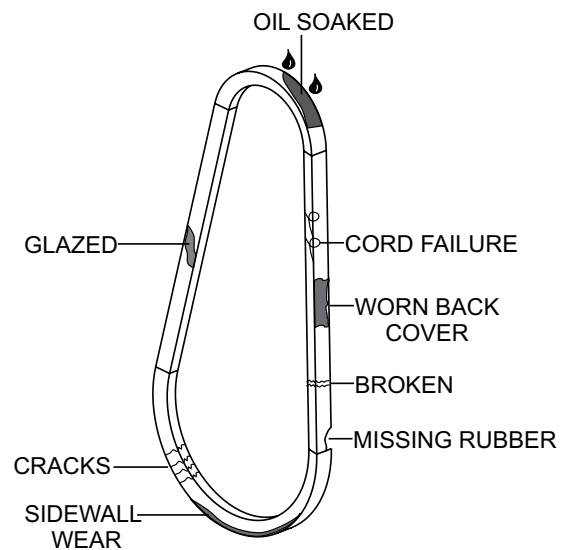

Figure 59. V-Belt Inspection

ENGINE OIL (CHECK DAILY)

1. When checking or adding oil, place the machine so the engine is level.
2. Pull the engine oil dipstick from its holder.
3. Determine if engine oil is low. Oil level should be between the upper and lower limit (Figure 60) on the dipstick.

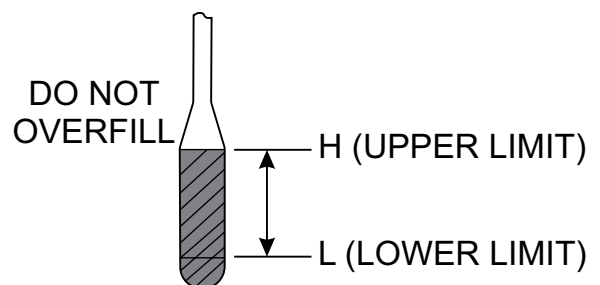

Figure 60. Dipstick Engine Oil Level

- If oil level is low, add correct amount of engine oil to bring oil level to a normal safe level (See Recommended Viscosity Grades, Table 15).
- Allow enough time for any added oil to make its way to the oil pan before rechecking.

Table 15. Oil Selection Chart		OIL: SAE	
°F	°C		
122	50		
104	40	5W/30	5W/40
86	30	10W	10W/30
68	20	10W/40	15W/40
50	10	20W/20	30
32	0		40
-14	-10		
-4	-20		
-22	-30		
-40	-40		

DRAINING ENGINE OIL

- Run the engine until the engine coolant reaches a temperature of 140° (60°C) Turn the engine off.
- Remove the oil dipstick from its holder.
- Next, remove oil drain bolt and sealing washer and allow the oil to drain into a suitable container.

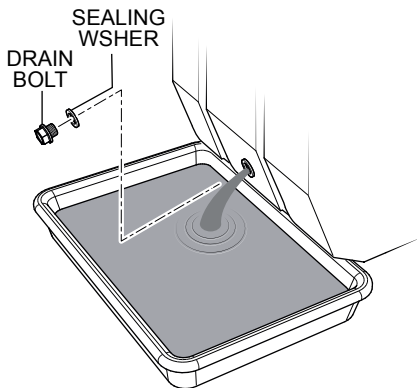

Figure 61. Draining Engine Oil

- After engine oil has been completely drained, reinstall drain bolt with sealing washer and tighten securely.

NOTICE

For composite oil pans always install a **new** sealing washer.

ENGINE OIL FILTER REPLACEMENT

- Clean the area around the lubricating oil filter head.
- Using an oil filter wrench (Figure 62), remove engine oil filter.

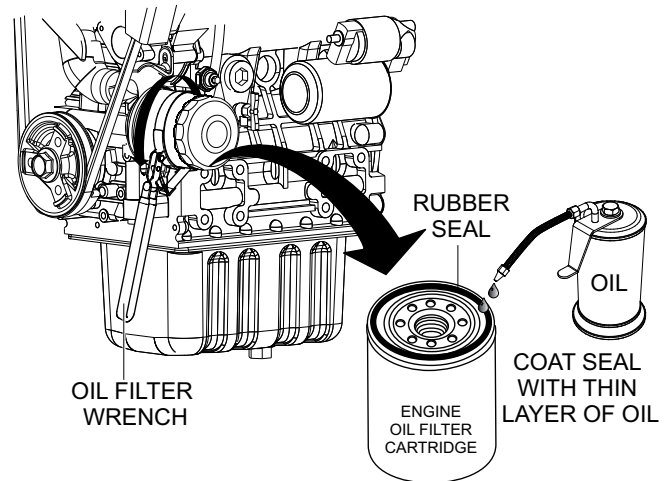

Figure 62. Engine Oil Filter Removal

- Coat the rubber seal (gasket) surface of oil filter (Figure 62) with clean 15W-40 engine oil.
- Install new oil filter first by hand until it makes contacts with the filter head surface. Tighten it another 3/4 turn using the filter wrench.
- Fill engine crankcase with high quality detergent oil classified "For Service CI-4. Fill to the upper limit of dipstick. **DO NOT** overfill. Reference Table 2 for engine crankcase oil capacity
- Run the engine for several minutes. Watch for oil leakage. Shut the engine down and allow it to sit for several minutes. Top off the oil to the upper limit on the dipstick.

FLUSHING OUT RADIATOR AND REPLACING COOLANT

WARNING

DO NOT remove the pressure cap from the radiator when the engine is hot! Wait until the coolant temperature is below 120°F (50°C) before removing pressure cap.

Heated coolant spray or steam can cause severe scalding and personal injury.

1. Remove the coolant (Figure 63) bolt or **OPEN** the drain valve on the radiator and allow the coolant to drain into a suitable container.

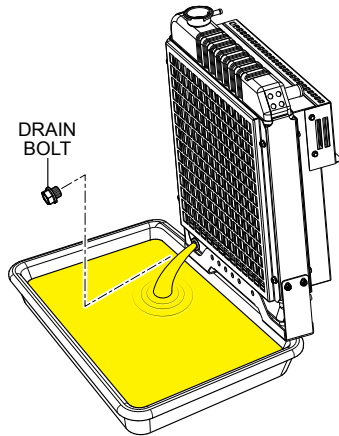

Figure 63. Draining Engine Coolant

2. Check hoses for softening and kinks. Check clamps for signs of leakage.
3. Tighten water cock and replace the overflow tank.
4. Replace with coolant as recommended by the engine manufacturer.
5. Close radiator cap tightly.
6. Flush the radiator by running clean tap water through radiator until signs of rust and dirt are removed. **DO NOT** clean radiator core with any objects, such as a screwdriver.

WARNING



Allow engine to **cool** when flushing out radiator. Flushing the radiator while hot could cause serious burns from water or steam.

RADIATOR CLEANING

The radiator (Figure 64) should be sprayed (cleaned) with a high pressure washer when excessive amounts of dirt and debris have accumulated on the cooling fins or tube. When using a high pressure washer, stand at least 5 feet (1.5 meters) away from the radiator to prevent damage to the fins and tube.

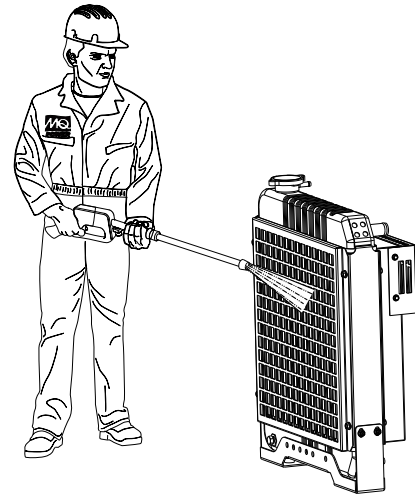

Figure 64. Radiator Cleaning

ENGINE BLOCK HEATING ELEMENT AND INTERNAL BATTERY CHARGER 120 VAC INPUT RECEPTACLES (OPTIONAL)

This generator can be equipped as an *option* with a **engine block heating element** and an **internal battery charger**. They are provided with electric cords to connect to a commercial power source.

The engine block heating element and internal battery charger both require 120 VAC in order to operate. A receptacle (Figure 65) has been provided on the output terminal panel to allow commercial power to be applied.

These units will **ONLY** function when commercial power has been supplied to them. When using extension cords, refer to Table 6 for the correct size and length.

When using the generator in **hot** climates there is no need to apply power to jacket water heater. However, if the generator will be used in **cold** climates, it is best to apply power to the jacket water heater at all times.

If the generator will be used daily, the battery should normally not require charging. If the generator will be idle (not used) for long periods of time, apply power to the battery charger receptacle via commercial power using a power cord of adequate size.

NOTICE

If the generator will be idle (not used) for long periods of time and to ensure adequate starting capability, always have power applied to the generator's internal battery charger.

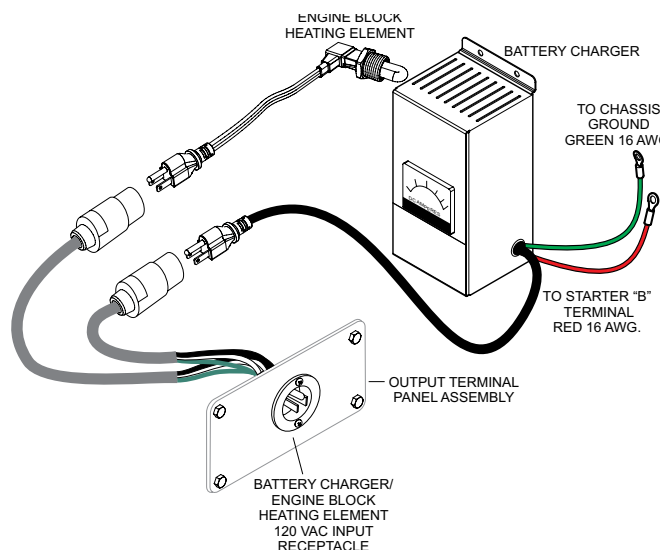

Figure 65. Battery Charger and Jacket Water Heater (Option)

GENERATOR STORAGE

For long term storage of the generator the following is recommended:

- Drain the fuel tank completely. Treat with a fuel stabilizer if necessary.
- Completely drain the oil from the crankcase and refill if necessary with fresh oil.
- Clean the entire generator, internal and external.
- Cover the generating set and store in a clean, dry place.
- Disconnect the battery.
- Make sure engine coolant is at proper level.
- If generator is mounted on a trailer, jack trailer up and place on blocks so tires do not touch the ground or block and completely remove the tires.

EMISSION CONTROL

The emission control system employed with this Kubota diesel engine consist of a Diesel Oxidation Catalyst (DOC).

The DOC device (Figure 66) helps in filtering out large amounts of harmful Nitrogen Oxides (NOx) and Particulate Matter (PM) which are emitted by diesel engines. These exhaust emissions pose serious environmental and health risks. It is important to maintain and service the DOC emission safety device on a periodic basis.

Diesel Oxidation Catalyst (DOC)

The DOC does not filter particles it oxidizes them. This catalyst (honeycomb like structure) uses a chemical process to break down pollutants in the exhaust stream into less harmful components. In general this catalyst collects/burns accumulated particulates. The DOC contains palladium and platinum which serve as a catalysts to oxidize hydrocarbons and carbon monoxide.

EMISSION CARBON CHECK

Deposition of carbon (soot, unburned fuel) in the exhaust pipe line and muffler could cause not only system derates but also could lead to fires.

To reduce soot and unburned fuel, run the unit at rated power until the exhaust gas become mostly colorless every 250 hours operation time. More carbon will be generated when the unit operates at less then 30% of rated power. In this case, perform the above procedures more frequently.

NOTICE

Applying a large load suddenly to the unit when the carbon deposition is generated in the exhaust system could produce sparks and will lead to abnormal combustion. Therefore, apply load gradually and observe the exhaust gas color during the process.

NOTICE

Sparks may come out of the exhaust gas outlet during load operation. Make sure the unit's surrounding is free from any flammable material.

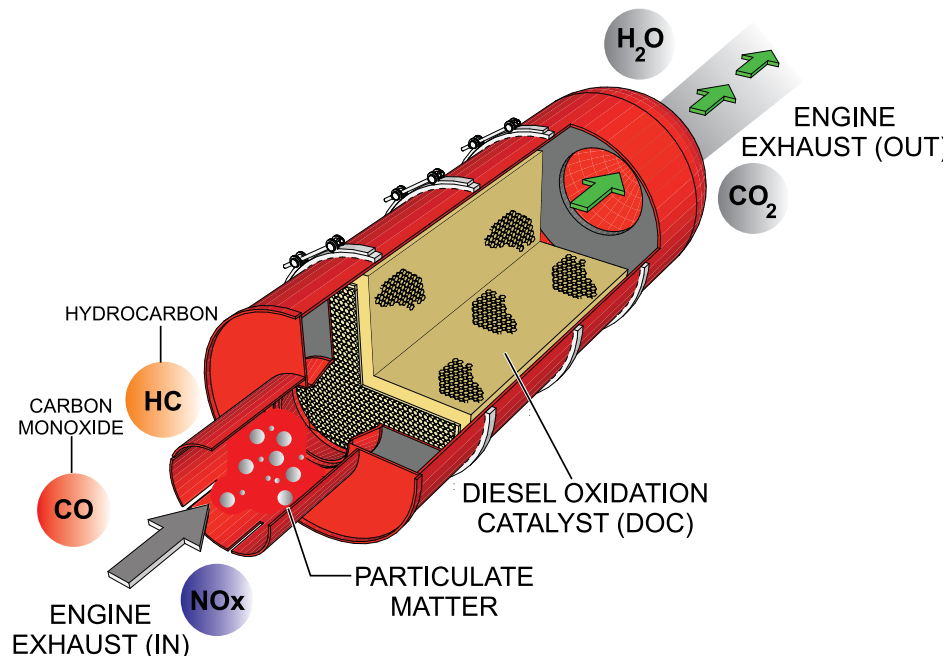

Figure 66. Diesel Oxidation Catalyst (DOC)

TROUBLESHOOTING DIAGNOSTICS

NOTICE

The engine controller of this generator diagnoses problems that arise from the engine control system and the engine itself.

ENGINE FAULT CODE DIAGNOSTIC PROCEDURES

1. Remove all loads from the generator and place all circuit breakers in the **OFF** position.
2. Shutdown the engine and open the control panel.
3. On the control panel, place the **diagnostic switch** (Figure 67) in the **ON** (up) position to start the diagnostic process.

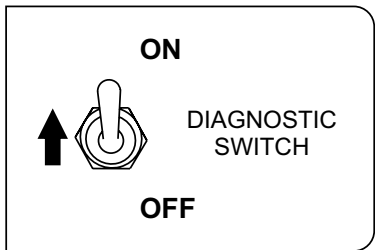

Figure 68. Diagnostic Switch (ON)

4. The Pre-Alarm diagnostic LED will display the following:
 - The pre-alarm diagnostic LED will (Figure 68) start **flashing** with a pattern associated with the fault 3 times at an interval of 2.4 seconds.

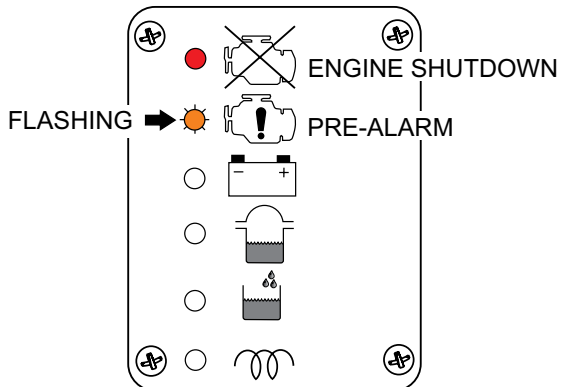

Figure 69. Pre-Alarm LED (Flashing)

- If there are more than 2 fault codes are detected, the pre-alarm diagnostic LED will repeat the detected fault codes blinking patterns in ascending order. After all the detected fault codes are shown, it will repeat the same sequence from the beginning.

- If no fault code is detected, the pre-alarm diagnostic LED will blink repeatedly at an interval of 2.4 seconds.

NOTICE

- When a fault has been detected, the fault code will automatically be saved as a previous code in the **ECM** even after the fault has been repaired.
- The pre-alarm diagnostic LED indicates the current fault code with the previous fault code in ascending order.
- When a fault occurs while the engine is running, the pre-alarm diagnostic LED will turn on indicating only the **current fault** has occurred. Please note that the blinking fault code pattern cannot be displayed while the engine is running.

NOTICE

For a complete understanding of error codes and troubleshooting procedures, refer to the enclosed engine instruction manual.

5. When diagnostic verification is complete be sure to place the **diagnostic switch** in the **OFF** position (Figure 69). The engine will not start if the diagnostic switch is left in the **ON** position.

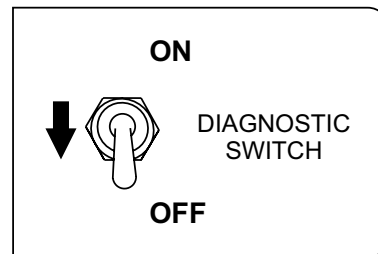

Figure 70. Diagnostic Switch (OFF)

TROUBLESHOOTING (GENERATOR)

Practically all breakdowns can be prevented by proper handling and maintenance inspections, but in the event of a breakdown, use Table 16 shown below for diagnosis of the Generator. If the problem cannot be remedied, consult our company's business office or service plant.

Table 16. Generator Troubleshooting		
Symptom	Possible Problem	Solution
No Voltage Output	AC Voltmeter defective?	Check output voltage using a voltmeter.
	Is wiring connection loose?	Check wiring and repair.
	Is AVR defective?	Replace if necessary.
	Defective Rotating Rectifier?	Check and replace.
	Defective Exciter Field?	Check and replace.
Low Voltage Output	Is engine speed correct?	Turn engine throttle lever to "High".
	Is wiring connections loose?	Check wiring and repair.
	Defective AVR?	Replace if necessary.
High Voltage Output	Is wiring connections loose?	Check wiring and repair.
	Defective AVR?	Replace if necessary.
Circuit Breaker Tripped	Short Circuit in load?	Check load and repair.
	Over current?	Confirm load requirements and reduce.
	Defective circuit breaker?	Check and replace.
	Over current Relay actuated?	Confirm load requirement and replace.

When the Emergency/Malfunction shutdown system has been activated, the engine will be stopped and the pre-alarm LED will indicate the malfunction by a series of flashing patterns. The flashing patterns and corrective action are shown below in Table 17. The flashing patterns consist of combinations of one or more long flashes and one or more short flashes.

Table 17. Engine/Generator Troubleshooting (Pre-Alarm LED)			
Type of Fault	Possible Fault	Pre-Alarm LED Indication	Solution
Engine Overspeed	115% or more rated RPM speed?	Long 1 Short 1	Check electronic governor
Low Oil Pressure	Oil pressure 7 psi (49 kPa) or greater?	Long 1 Short 2	Check oil level.
Insufficient Charge	No Voltage of Charging Genset?	Long 1 Short 3	Check wiring and repair.
High Water Temperature	Engine Overheat, 230° F (110° C)?	Long 1 Short 4	Check cooling system.
	Engine Overheat, 248° F (120° C)?	Long 1 Short 6	Check cooling system.
Emergency Stop	Emergency Stop signal detected?	Long 1 Short 5	Check and repair fault
Starter Motor Protection	Starter motor run for 12 seconds or more?	Long 1 Short 7	Check wiring and repair.
Rotation Sensor	Defective sensor, short circuit?	Long 2 Short 1	Check wiring and repair.
Solenoid	Defective solenoid, short circuit?	Long 2 Short 2	Check wiring and repair.
Water Temperature Sensor	Disconnection	Long 2 Short 4	Check connection.
	Short Circuit	Long 2 Short 5	Check sensor. Replace.
Charging Gen. Terminal	Disconnection	Long 2 Short 6	Check connections.
Over Voltage	VCC 18 volts or greater	Long 3 Short 1	Check overcurrent relay.

GENERATOR WIRING DIAGRAM

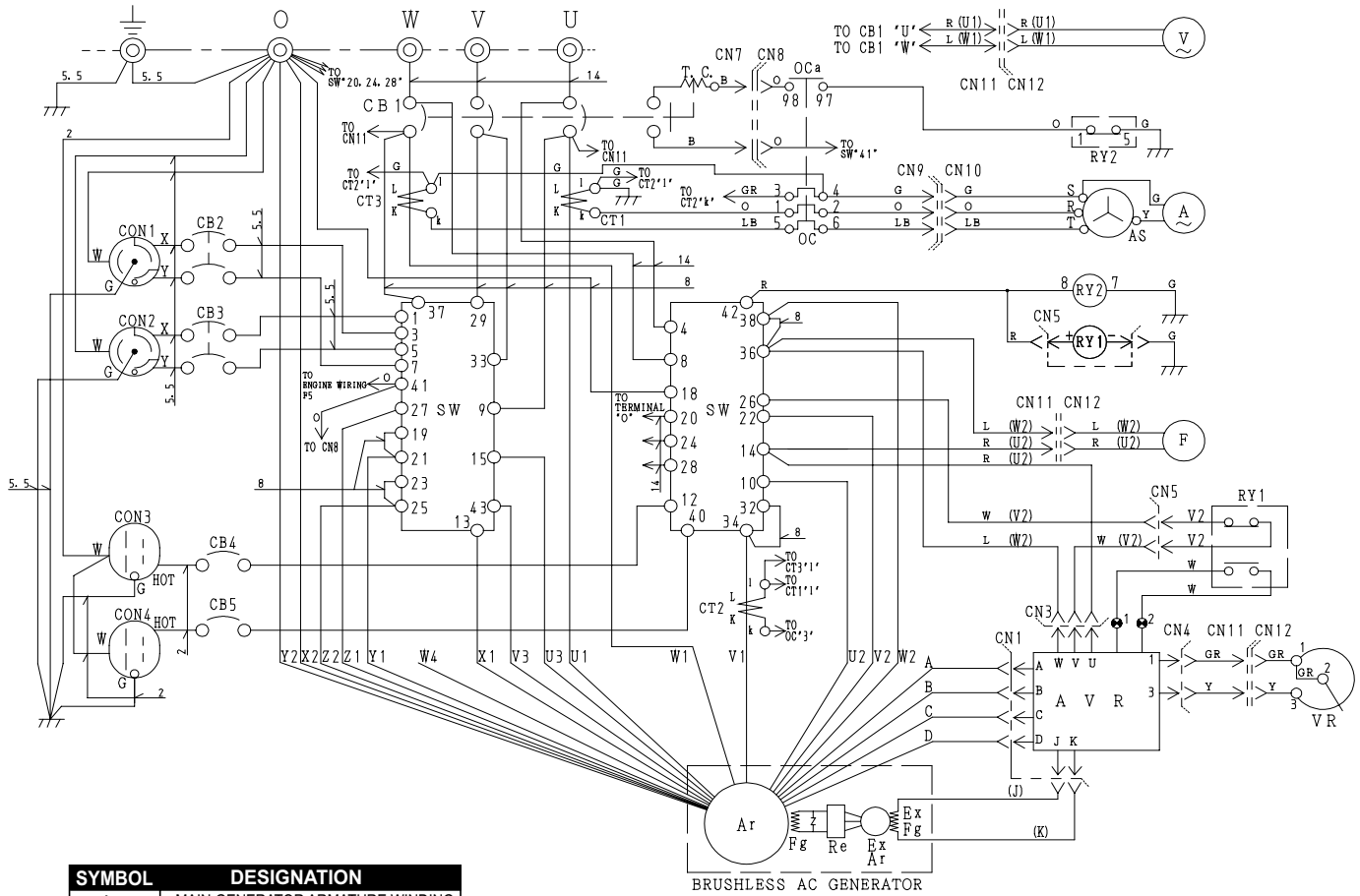

SYMBOL	DESIGNATION
Ar	MAIN GENERATOR ARMATURE WINDING
Fg	MAIN GENERATOR FIELD WINDING
ExAr	EXCITER ARMATURE WINDING
ExFg	EXCITER FIELD WINDING
Re	RECTIFIER
AVR	AUTOMATIC VOLTAGE REGULATOR
VR	VOLTAGE REGULATOR (RHEOSTAT)
CT 1,2,3	CURRENT TRANSFORMER
AS	CHANGE-OVER SWITCH, AMMETER
A	AC AMMETER
V	AC VOLTMETER
F	FREQUENCY METER
CB1	CIRCUIT BREAKER, 3P 110A
CB2, 3	CIRCUIT BREAKER, 2P 50A
CB4, 5	CIRCUIT BREAKER, 1P 20A
CON1, 2	RECEPTACLE, CS6369, 250 VAC @ 50 AMPS
CON3, 4	RECEPTACLE, GFCI, 125 VAC @ 20 AMPS X 2
OC	OVER CURRENT RELAY
SW	SELECTOR SWITCH
RY1	RELAY UNIT
RY2	RELAY UNIT

CURRENT TRANSFORMERS (CT1 ~ 3)	
REF. DES.	MARK AT CT
k	X1
l	NO MARK
K	H1
L	NO MARK

NOTE: EACH CABLE IS PASSED TWICE THROUGH CURRENT TRANSFORMERS CT1, CT2 AND CT3.

CONNECTOR ARRANGEMENT (WIRING VIEW)

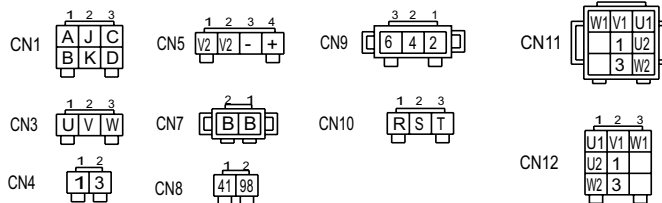

WIRE SIZE	CODE/WIRE COLOR			
125: 125 mm ²	B	BLACK	R	RED
100: 100 mm ²	L	BLUE	W	WHITE
80: 80 mm ²	BR	BROWN	Y	YELLOW
22: 22 mm ²	G	GREEN	LB	LIGHT BLUE
14: 14 mm ²	GR	GRAY	LG	LIGHT GREEN
8: 8 mm ²	V	VIOLET	O	ORANGE
5.5: 5.5 mm ²	P	PINK		
NO MARK WIRE SIZE: 1.25 mm ²				

ENGINE WIRING DIAGRAM

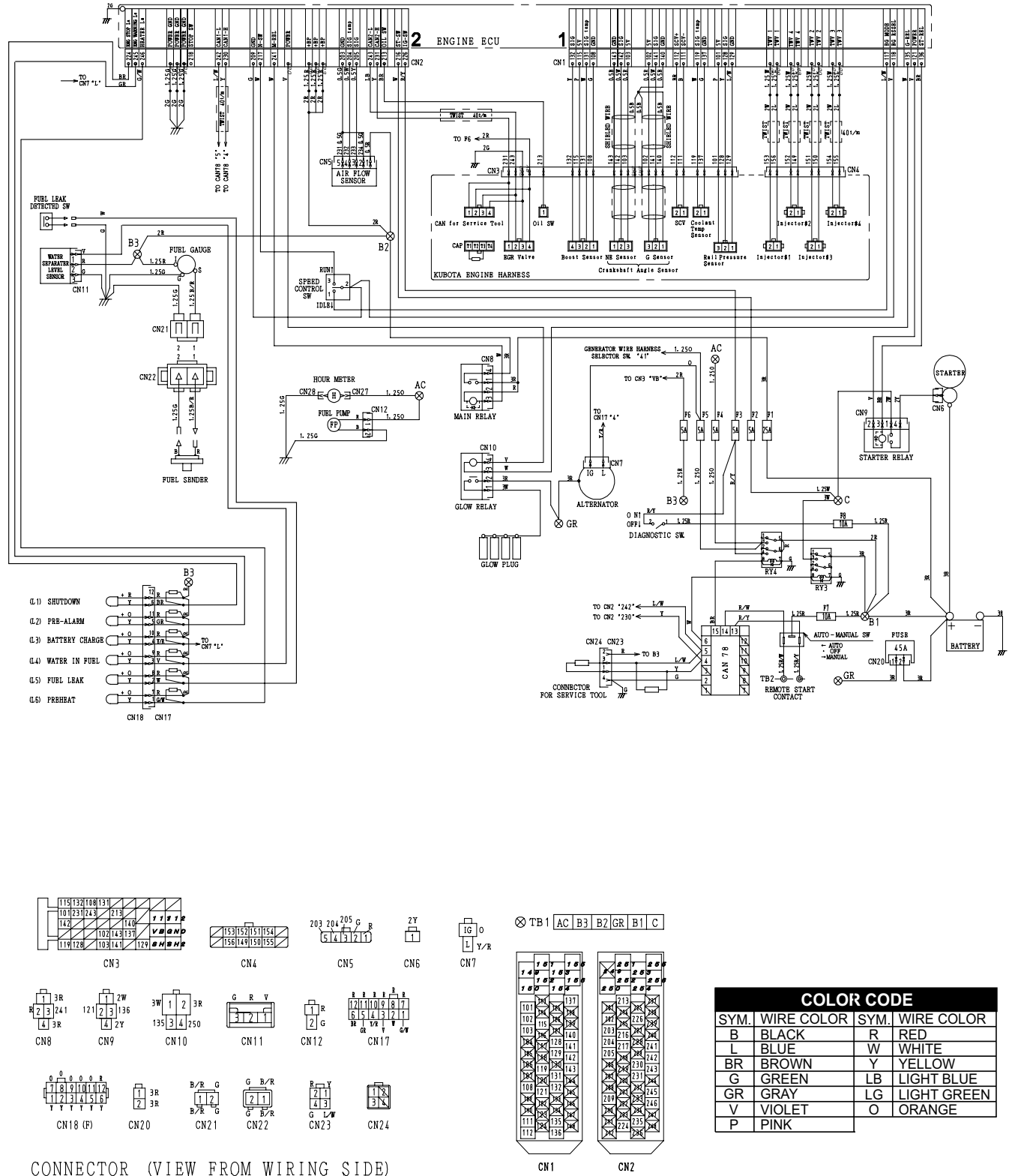

BATTERY CHARGER WIRING DIAGRAM

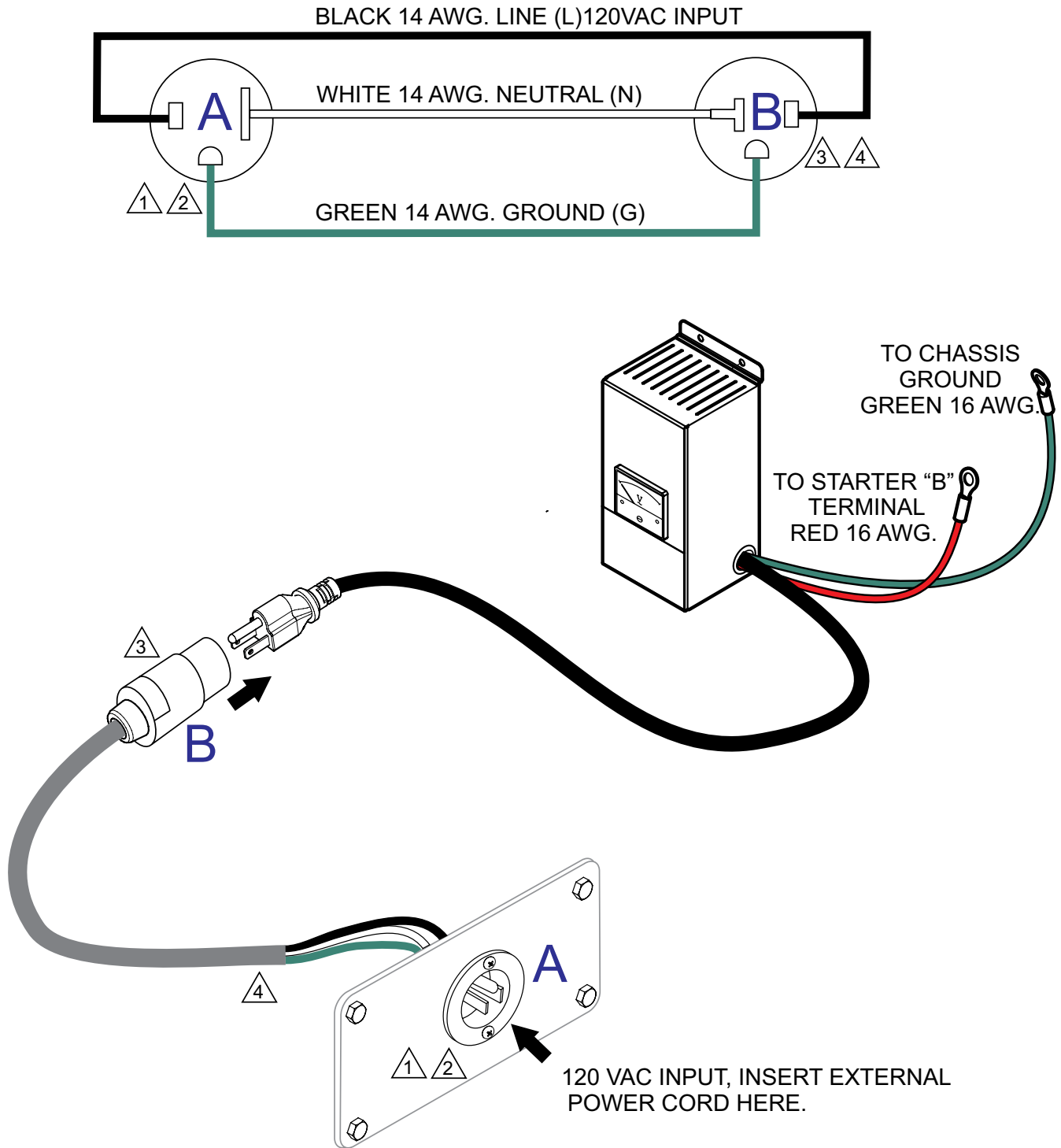

NOTES:

- ① NEMA 5-15, 15A, 120 VAC, P/N HBL5278C/HUBBLE RECEPTACLE.
- ② RECEPTACLE IS MOUNTED ON OUTPUT TERMINAL PANEL ASSY.
- ③ 20 AMP, 5-20R RECEPTACLE, P/N HBL5369C/HUBBLE RECEPTACLE.
- ④ CORD, CAROL 3/C 14 AWG., P/N EE56557.

ENGINE BLOCK HEATER WIRING DIAGRAM

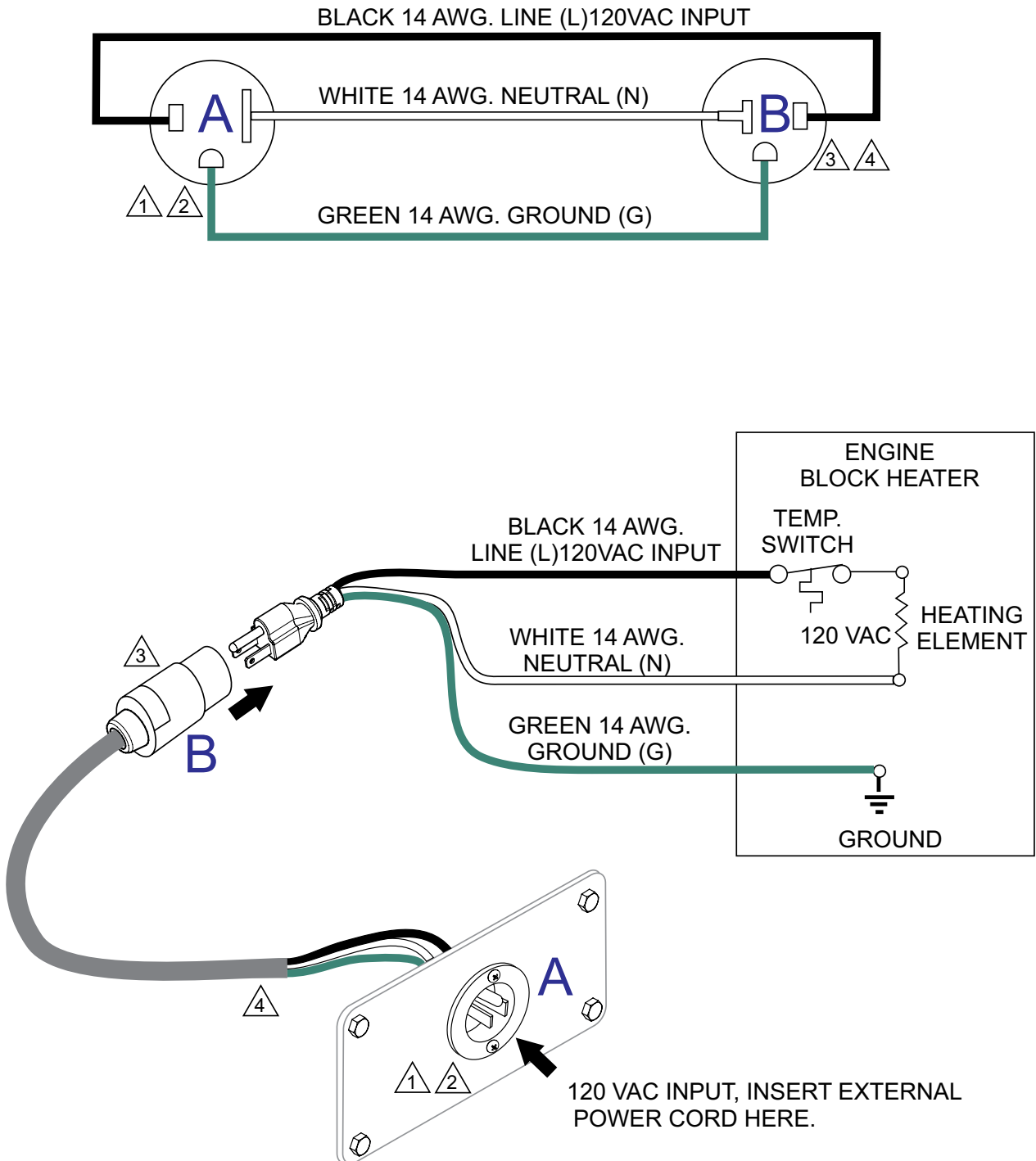

NOTES:

- ① NEMA 5-15, 15A, 120 VAC, P/N HBL5278C/HUBBLE RECEPTACLE.
- ② RECEPTACLE IS MOUNTED ON OUTPUT TERMINAL PANEL ASSY.
- ③ 20 AMP, 5-20R RECEPTACLE, P/N HBL5369C/HUBBLE RECEPTACLE.
- ④ CORD, CAROL 3/C 14 AWG., P/N EE56557.

OPERATION MANUAL

HERE'S HOW TO GET HELP

PLEASE HAVE THE MODEL AND SERIAL
NUMBER ON-HAND WHEN CALLING

UNITED STATES

Multiquip Corporate Office

18910 Wilmington Ave.
Carson, CA 90746
Contact: mq@multiquip.com

Tel. (800) 421-1244
Fax (310) 537-3927

Service Department

800-421-1244
310-537-3700

Technical Assistance

800-478-1244 Fax: 310-943-2238

MQ Parts Department

800-427-1244
310-537-3700

Fax: 800-672-7877

Warranty Department

800-421-1244
310-537-3700

Fax: 310-943-2249

CANADA

Multiquip

4110 Industriel Boul.
Laval, Quebec, Canada H7L 6V3
Contact: infocanda@multiquip.com

Tel: (450) 625-2244
Tel: (877) 963-4411
Fax: (450) 625-8664

UNITED KINGDOM

Multiquip (UK) Limited Head Office

Unit 2, Northpoint Industrial Estate,
Globe Lane,
Dukinfield, Cheshire SK16 4UJ
Contact: sales@multiquip.co.uk

Tel: 0161 339 2223
Fax: 0161 339 3226

© COPYRIGHT 2018, MULTIQUIP INC.

Multiquip Inc, the MQ logo and the MQ Power logo are registered trademarks of Multiquip Inc. and may not be used, reproduced, or altered without written permission. All other trademarks are the property of their respective owners and used with permission.

This manual MUST accompany the equipment at all times. This manual is considered a permanent part of the equipment and should remain with the unit if resold.

The information and specifications included in this publication were in effect at the time of approval for printing. Illustrations, descriptions, references and technical data contained in this manual are for guidance only and may not be considered as binding. Multiquip Inc. reserves the right to discontinue or change specifications, design or the information published in this publication at any time without notice and without incurring any obligations.

Your Local Dealer is:

Manufactured for
MQ Power Inc.
by
DENYO CO., LTD, JAPAN

